

# HP 432A POWER METER

## SERIAL NUMBERS

This supplement applies directly to instruments with serial numbers prefixed 1141A.

With changes described in Appendix I, this manual also applies to instruments with serial numbers prefixed 812-, 840-, 843-, 904-, 919-, 937-, 968-, 992-, and 1102A.

For additional important information about serial numbers see INSTRUMENTS IDENTIFICATION in Section I.



**HEWLETT  
PACKARD**

© Copyright HEWLETT-PACKARD COMPANY 1968, 1972  
1501 PAGE MILL ROAD, PALO ALTO, CALIFORNIA, U.S.A.

Manual Part No. 00432-90009

E0672

Microfiche Part No. 00432-90029

## TABLE OF CONTENTS

Section	Page	Section	Page	
I	GENERAL INFORMATION . . . . .	1-1	V	MAINTENANCE (Cont)
	1-1. Description . . . . .	1-1	5-15.	Initial Setup . . . . .
	1-5. Instrument Identification . . . . .	1-1	5-16.	Meter Accuracy Test . . . . .
II	INSTALLATION . . . . .	2-1	5-17.	Calibration Factor Test . . . . .
	2-1. Initial Inspection . . . . .	2-1	5-18.	Meter Linearity Check . . . . .
	2-2. Mechanical Check . . . . .	2-1	5-19.	Zero Carryover Test . . . . .
	2-4. Performance Checks . . . . .	2-1	5-20.	Line Zero Range Check . . . . .
	2-6. Damage Claims . . . . .	2-1	5-21.	432A Calibration Without
	2-9. Three-Conductor Power Cable	2-1		8477A Calibrator . . . . .
	2-12. Primary Power Requirements	2-1	5-24.	Calibration Procedure 1 . . . . .
	2-14. Internal Battery Operation . . . . .	2-1	5-26.	Calibration Procedure 2 . . . . .
	2-16. Battery Installation . . . . .	2-1	5-27.	Cover Removal and Replace-
	2-17. Battery Storage . . . . .	2-1		ment . . . . .
	2-19. Rack Mounting . . . . .	2-1	5-29.	Top Cover Removal . . . . .
	2-21. Combining Case . . . . .	2-1	5-30.	Top Cover Replacement . . . . .
	2-23. Adapter Frames . . . . .	2-2	5-31.	Bottom Cover Removal . . . . .
	2-25. Repacking for Shipment . . . . .	2-2	5-32.	Bottom Cover Replacement . . . . .
III	OPERATING INFORMATION . . . . .	3-1	5-33.	Adjustment Procedures . . . . .
	3-1. Introduction . . . . .	3-1	5-34.	Initial Setup . . . . .
	3-4. Controls, Connectors and Indi-	3-1	5-35.	Mechanical Meter Adjust-
	cators . . . . .	3-1		ment . . . . .
	3-12. Battery Operation . . . . .	3-1	5-36.	Bridge Amplifier Tests . . . . .
	3-17. Microwave Power Measure-	3-2	5-37.	Meter and Recorder Output
	ment Accuracy . . . . .	3-2		Calibration . . . . .
	3-23. Calibrator Factor and Effective	3-2	5-38.	Battery Charger Adjustment
	Efficiency . . . . .	3-2		(Option 01 Only) . . . . .
	3-27. Precision Power Measurement	3-2	5-39.	Battery Removal . . . . .
	3-28. General . . . . .	3-2	5-40.	Isolating Trouble in Transistor
	3-30. Measurement Procedure . . . . .	3-2		Circuits . . . . .
IV	PRINCIPLES OF OPERATION . . . . .	4-1	5-46.	Out-of-Circuit Testing . . . . .
	4-1. Simplified Description . . . . .	4-1	5-48.	Component Replacement in
	4-5. Functional Block Diagram . . . . .	4-1		Etched Circuits . . . . .
V	MAINTENANCE . . . . .	5-1	5-50.	Axial-Lead Components . . . . .
	5-1. Introduction . . . . .	5-1	5-52.	Other Components . . . . .
	5-3. Content . . . . .	5-1	VI	REPLACEABLE PARTS . . . . .
	5-4. Performance Tests . . . . .	5-1	6-1.	Introduction . . . . .
	5-6. Adjustments . . . . .	5-1	6-3.	Ordering Information . . . . .
	5-10. Test Equipment . . . . .	5-1	VII	TROUBLESHOOTING, SCHEMATICS,
	5-12. Service Information . . . . .	5-1		AND COMPONENT LOCATIONS . . . . .
	5-14. 432A Performance Tests with	5-1	7-1.	Introduction . . . . .
	8477A Calibrator . . . . .	5-1	7-5.	Troubleshooting . . . . .
			7-8.	Schematics . . . . .
			7-12.	AAA1 Auto Zero Assembly . . . . .
			7-14.	Test Conditions . . . . .

## LIST OF TABLES

Number	Title	Page	Number	Title	Page
1-1.	Specifications . . . . .	1-1	7-4.	Compensation Bridge Troubleshooting	7-6
1-2.	Thermistor Mounts for the 432A . . . . .	1-2	7-5.	Auto-Zero Troubleshooting . . . . .	7-7
5-1.	Recommended Test Equipment . . . . .	5-0	7-6.	Chopping and Summing Circuit Troubleshooting . . . . .	7-7
5-2.	Meter Accuracy Test . . . . .	5-2	7-7.	5 kHz Multivibrator Troubleshooting . . . . .	7-7
5-3.	Calibration Factor Test . . . . .	5-2	7-8.	Range Amplifier Troubleshooting . . . . .	7-7
5-4.	Performance Test Card . . . . .	5-5	7-9.	Calibrator Factor Amplifier Troubleshooting . . . . .	7-7
5-5.	Out-of-Circuit Transistor Resistance Measurements . . . . .	5-11	7-10.	Pulse Width Modulator and Meter Troubleshooting . . . . .	7-7
5-6.	Etched Circuit Soldering Equipment . . . . .	5-13	7-11.	Battery Charger Troubleshooting . . . . .	7-9
5-7.	Safe Ohmmeter Range for Transistor Resistance Measurements . . . . .	5-14	7-12.	Power Supply Troubleshooting . . . . .	7-9
6-1.	Replaceable Parts . . . . .	6-2	AI-1.	Manual Changes . . . . .	AI-2
6-2.	Code List of Manufacturers . . . . .	6-6	AI-2.	Summary of Changes by Component . . . . .	AI-2
7-1.	Schematic Notes . . . . .	7-2	AI-3.	Back-dating for Table 6-1 (Change C) . . . . .	AI-4
7-2.	Overall Troubleshooting . . . . .	7-5	AI-1.	432A Power Meter Long Cable Options	AI-1
7-3.	RF Bridge Troubleshooting . . . . .	7-6			

## LIST OF ILLUSTRATIONS

Number	Title	Page	Number	Title	Page
1-1.	HP Model 432A Power Meter . . . . .	1-0	7-5.	Model 432A Bottom View, Component Locations . . . . .	7-6
1-2.	Instrument Identification . . . . .	1-1	7-6.	Model 432A Front Panel Interior . . . . .	7-6
2-1.	Sub-module Installation in Rack Adapter Frame . . . . .	2-2	7-7.	A1 Bridge Assembly, Component Locations . . . . .	7-10
2-2.	HP Model 1051A Combining Case Instrument Installation . . . . .	2-2	7-8.	Model 432A Rear Panel Interior . . . . .	7-10
3-1.	Precision Power Measurements . . . . .	3-3	7-9.	RF and Compensation Bridge Schematic Diagram . . . . .	7-11
3-2.	Front Panel Controls, Connectors and Indicators . . . . .	3-4	7-10.	Model 432A Switches . . . . .	7-12
3-3.	Rear Panel Controls and Connectors . . . . .	3-6	7-11.	A2 Meter Logic Assembly, Component Locations . . . . .	7-13
3-4.	Turn On and Zeroing Procedure . . . . .	3-8	7-12.	Meter Logic Schematic Diagram . . . . .	7-13
4-1.	Model 432A Simplified Block Diagram . . . . .	4-0	7-13.	A2 Meter Logic Assembly, Power Supply Component Locations . . . . .	7-15
4-2.	Model 432A Block Diagram . . . . .	4-3	7-14.	A7 Battery Charging Circuit (Option 01) Component Locations . . . . .	7-15
4-3.	Model 432A RF Bridge Talking Schematic . . . . .	4-4	7-15.	Power Supply, Schematic Diagram . . . . .	7-15
4-4.	Model 432A Meter Logic Talking Schematic . . . . .	4-6	7-16.	Thermistor Cable Wiring Diagram . . . . .	7-16
4-5.	Model 432A Power Supply Talking Schematic . . . . .	4-8	AI-1.	Meter Logic Schematic Back-Dating (Change C) . . . . .	AI-7
5-1.	Check and Adjustment Test Setup . . . . .	5-1	AI-2.	A2 Meter Logic Assembly Component Locations Back-Dating (Change C) . . . . .	AI-8
5-2.	Zero Carryover Test Setup . . . . .	5-3	AI-3.	A2 Meter Logic Assembly, Power Supply Component Locations Back-Dating (Change C) . . . . .	AI-8
5-3.	Bridge Amplifier Test . . . . .	5-10	AI-4.	432A Rear Panel Interior Back-Dating (Change G) . . . . .	AI-9
5-4.	Transistor Biasing and Operating Characteristics . . . . .	5-12	AI-5.	432A Front Panel Interior Back-Dating (Change I) . . . . .	AI-9
7-1.	Servicing Block Diagram . . . . .	7-3			
7-2.	Model 432A Top Internal View . . . . .	7-4			
7-3.	Model 432A Waveforms . . . . .	7-4			
7-4.	Model 432A Test Point Locations . . . . .	7-5			

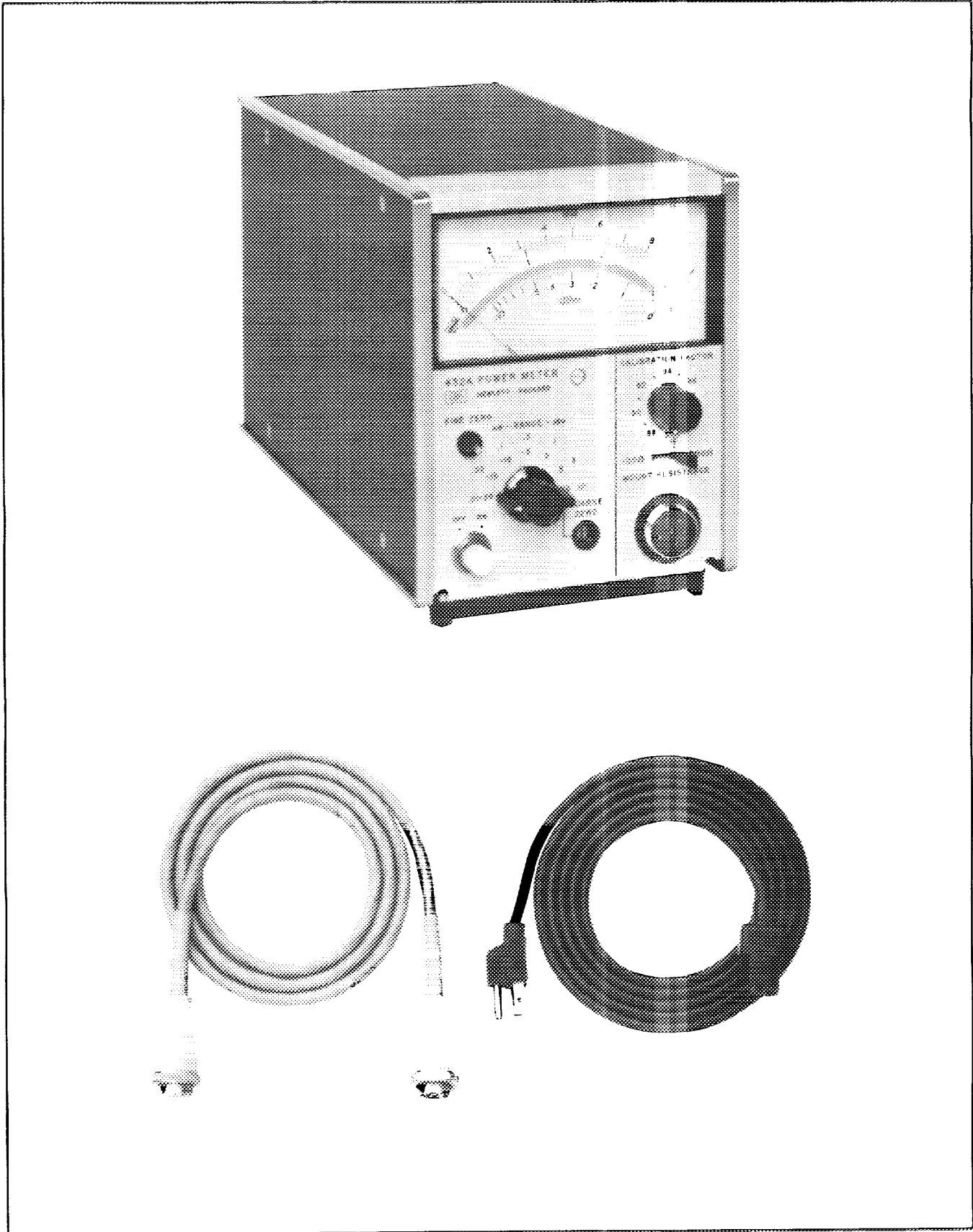

Figure 1-1. HP Model 432A Power Meter

## SECTION I GENERAL INFORMATION

### 1-1. DESCRIPTION.

1-2. The Hewlett-Packard Model 432A Power Meter, with HP temperature-compensated thermistor mounts, measures RF power from 10 microwatts (-20 dBm) to 10 milliwatts (+10 dBm) full scale with 1% of full scale accuracy from 10 MHz to 40 GHz. With a selector switch, the instrument normalizes the power meter reading to compensate for the Calibration Factor of a thermistor mount used for a given measurement. For portable operation, Option 01 instruments have a rechargeable nickel-cadmium battery. See Table 1-1 for complete specifications.

1-3. The Model 432A has provision for dc substitution measurements and for power meter calibration. An output is provided for recorders or digital voltmeter readout.

1-4. Accessories. Two accessories are supplied with the Model 432A Power Meter: a 7.5-foot (2290 mm) detachable power cable and a 5-foot (1520 mm) cable that connects the thermistor mount to the meter. Thermistor mounts are available but not supplied with the power meter (refer to Table 1-2). Table 1-1 lists those accessories supplied and also those available.

### 1-5. INSTRUMENT IDENTIFICATION.

1-6. Hewlett-Packard instruments are identified by an 8- or 10-digit serial number. The first three digits are the Serial Prefix. To properly match a manual with the instrument to which it applies, the prefix on the instrument must be the same as the prefix at the front of the manual. If the numbers are different, information is supplied either on yellow Manual Change Supplements, or in an Appendix in the Manual. If the change information is missing, contact your HP Sales Office (Sales Offices are listed at the back of the Manual).

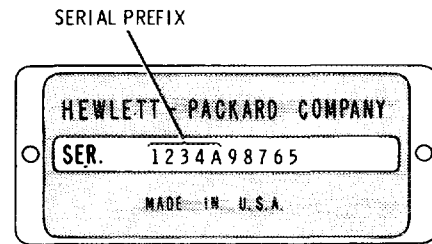

Figure 1-2. Instrument Identification

Table 1-1. Specifications

<p><b>Instrument Type:</b> Automatic, self-balancing power meter for use with temperature-compensated thermistor mount.</p> <p><b>Power Range:</b> 7 ranges with full-scale readings of 10, 30, 100, and 300 <math>\mu</math>W, 1, 3 and 10 mW; also calibrated in dBm from -20 dBm to +10 dBm full scale in 5-dB steps.</p> <p><b>Accuracy:</b> <math>\pm 1\%</math> of full scale on all ranges (<math>+0^\circ\text{C}</math> to <math>+55^\circ\text{C}</math>).</p> <p><b>Calibration Factor Control:</b> 13-position switch normalizes meter reading to account for thermistor mount Calibration Factor. Range: 100% to 88% in 1% steps.</p> <p><b>Thermistor Mount:</b> External temperature-compensated thermistor mounts required for operation (see Table 1-2).</p> <p><b>Meter:</b> Taut-band suspension, individually computer-calibrated, mirror-backed scales. Milliwatt scale more than 4-1/4 inches (108 mm) long.</p>	<p><b>Zero Carryover:</b> Less than <math>\pm 0.5\%</math> of full scale when zeroed on most sensitive range.</p> <p><b>Fine Zero:</b> Automatic, operated by toggle switch.</p> <p><b>Recorder Output:</b> 1.000 volt into open circuit corresponds to full-scale meter deflection (1.0 on 0-1 scale) <math>\pm 0.5\%</math>; 1000-ohm output impedance, BNC connector.</p> <p><b>RFI:</b> Meets all conditions specified in MIL-I-6181D.</p> <p><b>Power:</b> 115 or 230 Vac <math>\pm 10\%</math>, 48 to 440 Hz, 1-1/2 watts. Optional rechargeable battery provides up to 20 hours continuous operation. Automatic battery recharge.</p> <p><b>Weight:</b> Net 6-1/2 lb (3 kg).</p> <p><b>Weight with Optional Battery Pack:</b> Net 9-1/4 lb (4,2 kg).</p>
--	---

Table 1-1. Specifications (Cont.)

**Dimensions:**

**NOTE**  
 DIMENSIONS IN INCHES AND MILLIMETERS!  
 (A) FOR TOTAL LENGTH INCLUDING KNOBS  
 ADD 1 IN. (25.4 MM)  
 (B) FOR HEIGHT INCLUDING FEET  
 ADD 7/16 IN. (11 MM)

**Combining Cases**  
 1051A, 11-1/4 in. (286 mm) deep.  
 1052A, 16-3/8 in. (416 mm) deep.

The combining cases accept the 1/3-module HP instruments for bench use or rack mounting. See 1051A data sheet for details.

**Options:**  
 001: Rechargeable battery installed, provides up to 20 hours continuous operation.  
 002: Rear thermistor mount input connector wired in parallel with front panel input connector.  
 003: Input connector placed on rear panel instead of front.

**Note**  
 Thermistor mount cable impedance is part of the 432A input bridge circuit. For cables 20 feet long and over, the bridge is matched to specific cable options, so the various cables should not be interchanged.

**Accessories Furnished:** 5-ft (1.42 m) cable for HP temperature compensated thermistor mounts; 7-1/2 ft (2.29 m) power cable, NEMA plug.

**Accessories Available:**  
 00432-6016 Rechargeable Battery Pack for field installation.  
 5060-0797 Rack Adapter Frame (holds three instruments the size of the 432A).  
 8477A Power Meter Calibrator.  
 11076A Carrying Case.

009: 10-foot (3.05 m) cable for 100-ohm or 200-ohm mount.  
 010: 20-foot (6.10 m) cable for 100-ohm or 200-ohm mount.  
 011: 50-foot (15.24 m) cable for 100-ohm or 200-ohm mount.  
 012: 100-foot (30.48 m) cable for 100-ohm or 200-ohm mount.  
 013: 200-foot (60.96 m) cable for 100-ohm or 200-ohm mount.

Table 1-2. Thermistor Mounts for the 432A

HP Model	Frequency Range (GHz)	Operating Resistance (Ohms)
<b>COAXIAL MOUNTS:</b>		
478A (Type N Connector)	0.01-10	200
8478B (Type N Connector)	0.01-18	200
8478B-Option 11 (APC-7 Connector)	0.01-18	200
<b>WAVEGUIDE MOUNTS:</b>		
S486A	2.6-3.95	100
G486A	3.95-5.85	100
J486A	5.3-8.2	100
H486A	7.05-10	100
X486A	8.2-12.4	100
M486A	10-15	100
P486A	12.4-18	100
K486A	18-26.5	200
R486A	26.5-40	200
<b>WAVEGUIDE MOUNT ACCESSORIES:</b>		
11515A: Circular Flange Adapter for K486A.		
11516A: Circular Flange Adapter for R486A.		

## SECTION II

### INSTALLATION

#### 2-1. INITIAL INSPECTION.

##### 2-2. MECHANICAL CHECK.

2-3. If damage to the shipping carton is evident, ask that the carrier's agent be present when the instrument is unpacked. Inspect the instrument for mechanical damage. Also check the cushioning material for signs of severe stress.

##### 2-4. PERFORMANCE CHECKS.

2-5. The electrical performance of the Model 432A should be verified upon receipt. Performance checks suitable for incoming inspection are given in Section V, Maintenance.

##### 2-6. DAMAGE CLAIMS.

2-7. If the instrument is mechanically damaged in transit, notify the carrier and the nearest Hewlett-Packard field office immediately. A list of field offices is at the back of this manual. Retain the shipping carton and padding material for the carrier's inspection. The field office will arrange for replacement or repair of your instrument without waiting for claim settlements against the carrier.

2-8. Before shipment this instrument was inspected and found free of mechanical and electrical defects. If there is any deficiency, or if electrical performance is not within specifications, notify your nearest Hewlett-Packard Sales and Service Office.

#### 2-9. THREE-CONDUCTOR POWER CABLE.

2-10. To protect operating personnel, the National Electrical Manufacturers Association (NEMA) recommends that the instrument panel and cabinet be grounded. All Hewlett-Packard instruments are equipped with a three-conductor power cable which, when plugged into an appropriate receptacle, grounds the instrument. The offset pin on the power cable three-prong connector is the ground wire.

2-11. To preserve the protection feature when operating the instrument from a two-connector outlet, use a three-prong to two-prong adapter and connect the green pigtail on the adapter to ground.

#### 2-12. PRIMARY POWER REQUIREMENTS.

2-13. The Model 432A operates from 115 or 230 volts ac line voltage. Line frequency may vary from 48 to 440 Hz. A slide switch on the rear panel is moved to the correct position for the line voltage available. Before operating the equipment, ensure that the fuse installed in the instrument corresponds to the value marked on the panel for the line voltage available (1/8 amp slo-blow).

#### 2-14. INTERNAL BATTERY OPERATION.

2-15. Model 432A Option 001 instruments contain an internal battery and a battery charging assembly. By connecting the 432A to an ac source, the battery may be charged overnight. The battery can be maintained in the charging state indefinitely without damage. It will assume its full capacity, 1.25 ampere-hours, and will not charge in excess of that. This enables the instrument to operate for approximately 20 hours continuously without recharging.

##### 2-16. BATTERY INSTALLATION.

a. Set power switch to off and remove power plug from rear panel.

b. Remove top and bottom, and side instrument covers.

c. The battery is installed with the terminals toward the right hand side of the instrument when faced from the front. The two terminals on the battery fit into spaces provided on the circuit board.

d. Using the retaining nuts, fasten the battery firmly in place. Be careful not to short the battery terminals at any time as this may cause battery cell damage.

e. Install Assembly A7, battery charging board, in the space provided for it just ahead of the battery.

f. Reinstall instrument covers and adjust circuit. Instrument is now ready for operation.

##### 2-17. BATTERY STORAGE.

2-18. Store the battery at or below room temperature. Extended storage at high temperature will reduce the cell charge, but will not damage the battery if the storage temperature is below 140°F. Install the battery in the instrument and recharge before using Model 432A in battery operation.

#### 2-19. RACK MOUNTING.

2-20. Model 432A is narrower than full-rack width. It is what is termed a sub-modular unit. When used alone, the instrument can be bench mounted. When used in combination with other sub-modular units it may be bench or rack mounted. The HP 1051A and 1052A Combining Cases and Rack Adapter Frames are designed specifically for this purpose.

##### 2-21. COMBINING CASE.

2-22. A model 1051A Combining Case is shown in Figure 2-1. This case is full rack width and accepts varying combinations of submodular instruments. The case, purchased separately, is provided with a rack mounting kit. The combining case will hold three

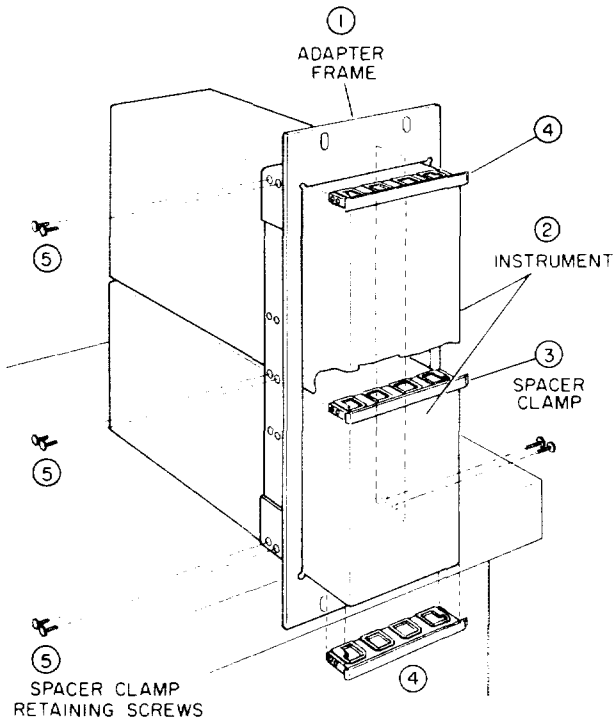

Figure 2-1. Sub-module Installation in Rack Adapter Frame

instruments the same size as the Model 432A. When instruments are installed in the combining case, they may be installed or removed individually.

2-23. ADAPTER FRAMES.

2-24. The 5060-0797 Adapter Frame is shown in Figure 2-2. The frame will accept a variety of submodular units in a manner suitable for rack mounting. Submodular units, in combination with any necessary spacers are assembled within the frame. A submodular unit cannot be removed individually.

2-25. REPACKING FOR SHIPMENT.

2-26. When returning an instrument to Hewlett-Packard use the original packing material. If the original foam type packing material is not available, contact an authorized HP Sales Office for assistance. If this is not possible, first protect the instrument surfaces by wrapping in heavy kraft paper or with sheets of cardboard flat against the instrument. Protect the instrument on all sides using approximately 4" of packing material and pack in a durable container. Mark the container clearly for proper handling and insure adequately before shipping.

2-27. When an instrument is returned to HP for service or repair, attach a tag to the instrument specifying the owner and desired action. All correspondence should identify the instrument by model number and full eight-digit serial number.

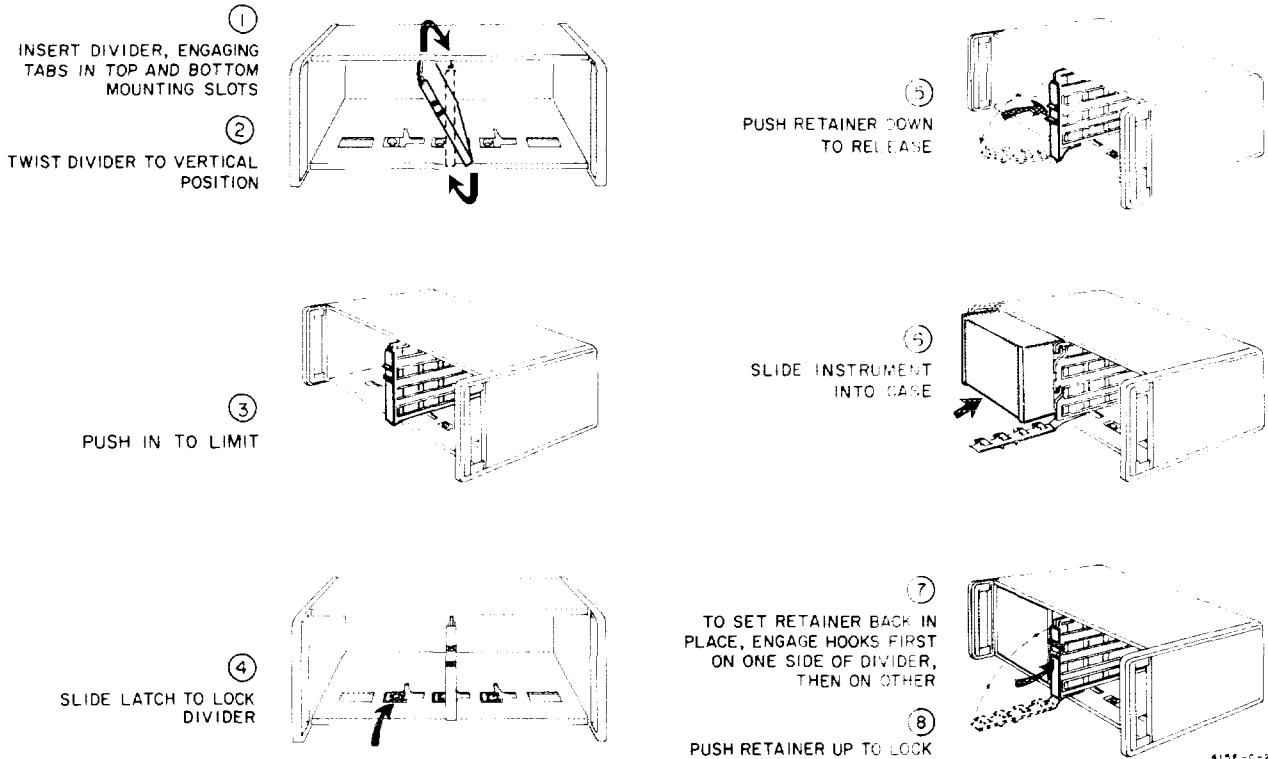

Figure 2-2. HP Model 1051A Combining Case Instrument Installation



## SECTION III

### OPERATING INFORMATION

#### 3-1. INTRODUCTION.

3-2. The Model 432A Power Meter operates with HP temperature-compensated thermistor mounts such as the 8478B and 478A Coaxial, and 486A Waveguide series. The frequency range of the 432A with these mounts in 50-ohm coaxial systems is 10 MHz to 18 GHz; in waveguide systems it is 2.6 GHz to 40 GHz. Full-scale power ranges are 10 microwatts to 10 milliwatts (-20 dBm to +10 dBm). Extended measurements may be made to 1 microwatt (-30 dBm). The total measurement capacity of the instrument is divided into seven ranges, selected by a front-panel RANGE switch.

3-3. This section describes general operating procedures and error analysis in microwave power measurement. Application Note 64, available on request from Hewlett-Packard, is a detailed analysis of microwave power measurement problems and techniques.

#### 3-4. CONTROLS, CONNECTORS, AND INDICATORS.

3-4. The front and rear panel controls, connectors, and indicators are explained in Figure 3-2. The descriptions are keyed to the corresponding items which are indicated on the figure.

3-6. The COARSE ZERO and FINE ZERO controls zero the meter. Zero carry-over from the most sensitive range to the other six ranges is within  $\pm 0.5\%$ . When the RANGE switch is set to COARSE ZERO, the meter indicates thermistor bridge unbalance, and the front panel COARSE ZERO adjust is for initial bridge balance. For best results, FINE ZERO the 432A on the particular meter range in use.

3-7. The CALIBRATION FACTOR switch provides discrete amounts of compensation for measurement uncertainties related to SWR and thermistor mount efficiency. The Calibration Factor value permits direct meter reading of the RF Power delivered to an impedance equal to the characteristic impedance ( $Z_0$ ) of the transmission line between the thermistor mount and the RF source. Calibration Factor values are marked on the label of each 8478B, 478A or 486A Thermistor Mount. For further details, see Paragraph 3-23.

3-8. The MOUNT RESISTANCE switch on the front panel compensates for three types of thermistor mounts. Model 486A waveguide mounts can be used by setting the MOUNT RESISTANCE switch to 100 $\Omega$  or 200 $\Omega$ , depending on the thermistor mount used (refer to Table 1-2). The 200 $\Omega$  position is used with Models 478A and 8478B Thermistor Mounts.

3-9. The rear-panel BNC connected labeled RECORDER provides an output voltage linearly propor-

tional to the meter current; 1 volt into an open circuit equals full-scale meter deflection. This voltage is developed across a 1K resistor; therefore, when a recorder with a 1K input impedance is connected to the RECORDER output, approximately .5 volt will equal full scale deflection. This loading of the RECORDER output has no effect on the accuracy of the 432A panel meter.

3-10. A digital voltmeter can be connected to the rear panel RECORDER output for more resolution of power meter readings. When a voltmeter with input impedance greater than 1 megohm is connected to the RECORDER output, 1 volt equals full scale deflection.

3-11. The 432A has two calibration jacks ( $V_{RF}$  and  $V_{COMP}$ ) on the rear panel that can be used for precision power measurements. Instrument error can be reduced from  $\pm 1\%$  to  $\pm (0.2\%$  of reading  $+5\mu W$ ) of reading, depending on the care taken in measurement and on the accuracy of auxiliary equipment. For further information, see Paragraph 3-27.

#### 3-12. BATTERY OPERATION.

3-13. The Model 432A Option 001 instruments contain a rechargeable Nickel-Cadmium battery is factory-installed in Option 01 instruments. The same battery can be ordered and later installed on the basic instrument, thereby modifying the power meter to the Option 01 configuration. The battery installation kit, HP part number 00432-6016 (including battery charging circuit) may be ordered from the nearest HP Sales Office.

3-14. It is recommended that the Model 432A be battery-operated for up to eight hours, and then allowed to recharge eight hours, or overnight. Continuous battery operation is possible for up to about 20 hours, but then the battery must be recharged for about 20 hours.

3-15. The 432A automatically operates on its internal battery whenever the ac line power is disconnected and the POWER switch is ON. When the battery terminal voltage decreases far enough to force the power supply voltage regulator out of regulation, then the meter stops working and the meter indicator points to the red RECHG BAT. To recharge the battery, simply connect the 432A to ac line power, and turn it ON.

3-16. Battery Storage. Storage of the battery at or below room temperature is best. Extended storage at temperatures above room temperature will reduce cell charge, but will not damage the battery; however, the battery should not be stored where the temperature exceeds 60°C (+140°F).

### 3-17. MICROWAVE POWER MEASUREMENT ACCURACY.

3-18. A number of factors affect the overall accuracy of power measurement. The major sources of error are mismatch error, RF losses, and instrumentation error.

3-19. Mismatch Error. In a practical measurement situation, both the source and thermistor mount have SWR, and the source is seldom matched to the thermistor mount unless a tuner is used. The amount of mismatch loss in any measurement depends on the total SWR present. The impedance that the source sees is determined by the actual thermistor mount impedance, the electrical length of the line, and the characteristic impedance of the line,  $Z_0$ .

3-20. In general, neither the source nor the thermistor mount has  $Z_0$  impedance, and the actual impedances are known only as reflection coefficients, mismatch losses, or SWR. The power delivered to the thermistor mount - and hence the mismatch loss - can only be described as being somewhere between two limits. The uncertainty of power measurement due to mismatch loss increases with SWR. Limits of mismatch loss are generally determined by means of a chart such as the Mismatch Loss Limits charts in Application Note 64. The total mismatch loss uncertainty in power measurement is determined by algebraically adding the thermistor mount losses to the uncertainty caused by source and thermistor mount  $Z_0$  match.

3-21. RF Losses. RF losses account for the power entering the thermistor mount but not dissipated in the detection thermistor element. Such losses may be in the walls of a waveguide mount, the center conductor of a coaxial mount, capacitor dielectric, poor connections within the mount, or due to radiation.

3-22. Instrumentation Error. The degree of inability of the instrument to measure the substitution power supplied to the thermistor mount is called power meter accuracy or instrumentation error. Instrumentation error of the Model 432A is  $\pm 1\%$  of full scale,  $0^\circ\text{C}$  to  $+55^\circ\text{C}$ .

### 3-23. CALIBRATION FACTOR AND EFFECTIVE EFFICIENCY.

3-24. Calibration factor and effective efficiency are correction factors for improving power measurement accuracy. Both factors are marked on every HP thermistor mount. Calibration factor compensates for thermistor mount VSWR and RF losses whenever the thermistor mount is connected to an RF source without a tuner. Effective efficiency compensates for thermistor mount RF losses when a tuner is used in the measurement system.

3-25. When the 432A CALIBRATION FACTOR selector is set to the appropriate factor indicated on the thermistor mount, the power indicated by the meter is the power that would be delivered by the source to

a load impedance equal to  $Z_0$ . More accurately, the relationship between indicated power and the power available to a  $Z_0$  load is given by the following equation:

$$P_o = \frac{P_{\text{indicated}} (1 \pm \rho_s \rho_m)^2}{\text{Calibration Factor}}$$

where

$P_o$  = power available to a  $Z_0$  load

$\rho_s$  = source reflection coefficient

$\rho_m$  = thermistor mount reflection coefficient

$$\rho = \frac{\text{SWR} - 1}{\text{SWR} + 1}$$

Calibration factor does not compensate for source VSWR, or for multiple reflections between the source and the thermistor mount.

3-26. To minimize mismatch between the source and the thermistor mount without a tuner, insert a low SWR precision attenuator in the transmission line between the thermistor mount and the source. Since the mount impedance (and corresponding SWR) deviates significantly only at the high and low ends of a microwave band, it is generally unnecessary to use a tuner. A tuner or other effective means of reducing mismatch error is recommended when the source SWR is high or when more accuracy is required. For further details, there is a complete discussion of microwave power measurement with emphasis on modern techniques, accuracy considerations and sources of error available in Application Note 64.

### 3-27. PRECISION POWER MEASUREMENT.

#### 3-28. GENERAL.

3-29. Using precision instruments and careful procedures, measurement error can be reduced to  $\pm 0.2\%$  of reading  $+0.5 \mu\text{W}$ . The technique involves: 1) zeroing the bridge circuits and measuring the bridge amplifier output voltage difference with a digital voltmeter, then 2) connecting RF power to the thermistor mount and then measuring the bridge amplifier output voltage difference again, and 3) calculating the power from the two measurements. Figure 3-1 shows the instrument setup for dc substitution measurement. Use an HP Model 3440A DVM, with a 3443A Plug-in Unit or a digital voltmeter with equivalent accuracy.

#### 3-30. MEASUREMENT PROCEDURE.

a. Connect the DVM to the 432A rear panel  $V_{\text{comp}}$  and  $V_{\text{RF}}$  outputs. Be sure that the digital voltmeter input is isolated from chassis ground.

b. Turn off, or disconnect the RF power from the thermistor mount.

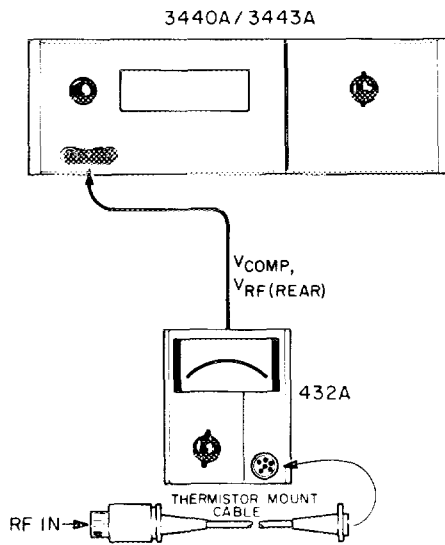

Figure 3-1. Precision Power Measurements

- c. Zero the 432A with the COARSE ZERO controls.
- d. Depress the FINE ZERO toggle, and measure the differential voltage ( $V_0$ ) between  $V_{comp}$  and  $V_{RF}$ .

$$V_0 = V_{COMP} - V_{RF}$$

- e. Release the FINE ZERO toggle, and turn on, or reconnect the RF power to the thermistor mount.

- f. Measure again the differential voltage ( $V_1$ ) between  $V_{RF}$  and  $V_{COMP}$ .

$$V_1 = V_{COMP} - V_{RF}$$

- g. Measure  $V_{COMP}$  to ground.

- h. Calculate incident RF power from the equation

$$P_{RF} = \frac{\frac{1}{4R} 2 V_{COMP} (V_1 - V_0) + V_0^2 - V_1^2}{\text{EFFECTIVE EFFICIENCY}}$$

where

$R$  is the thermistor mount resistance.

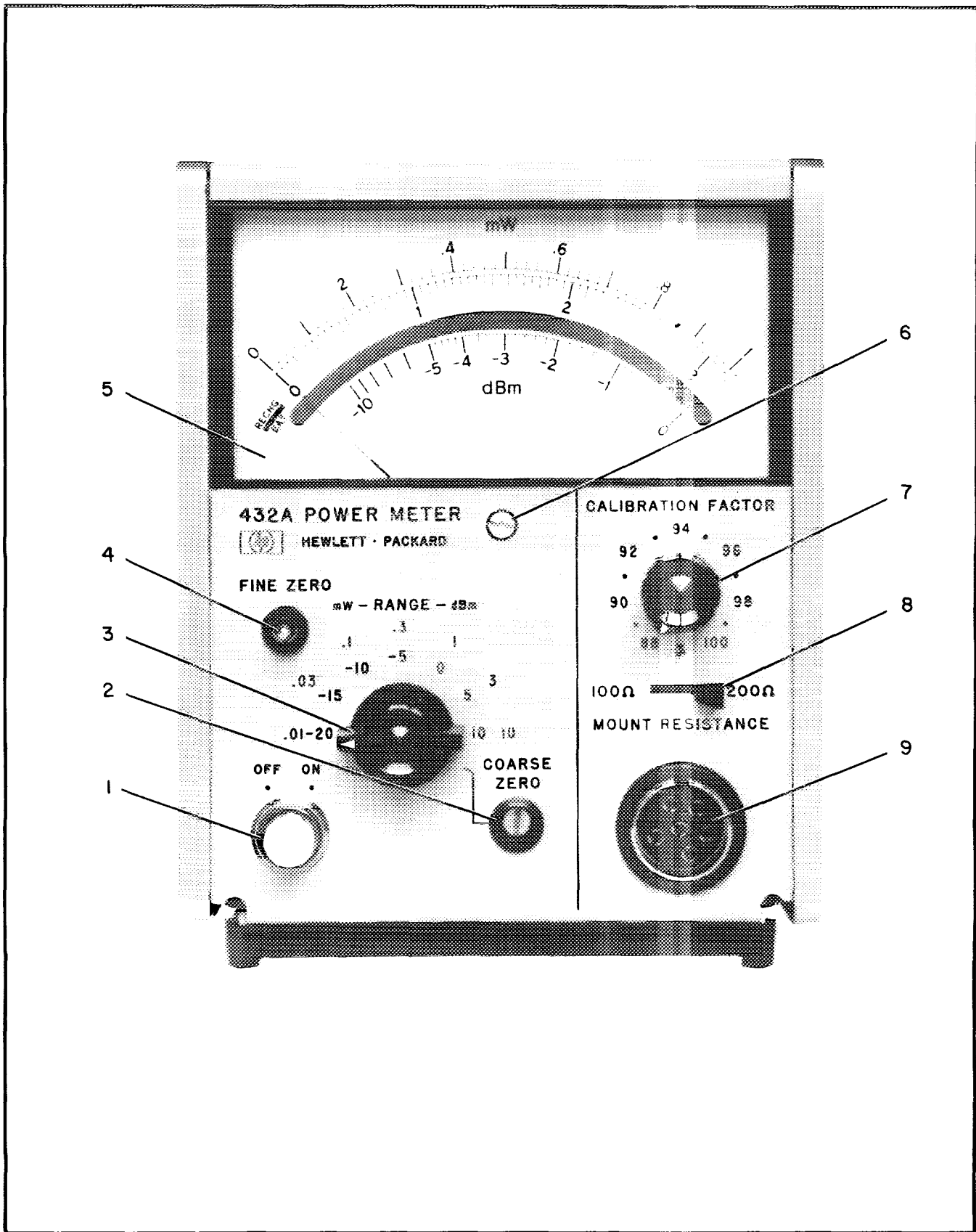

Figure 3-2. Front Panel Controls, Connectors and Indicators (Sheet 1 of 2)

1. **POWER.** Instrument power ON/OFF switch; connects either ac line voltage or internal battery (Option 01 only) to internal voltage regulator circuits. When ac power is on, optional battery charging circuit operates.
2. **COARSE ZERO.** Meter zero adjustment; set the RANGE selector to COARSE ZERO, turn OFF the RF power, and adjust to zero the meter.
3. **RANGE.** Power measurement range selector; selects ranges from 0.01 to 10 milliwatts (-20 to +10 dBm). COARSE ZERO setting is used to zero meter with no power applied to thermistor mount.
4. **FINE ZERO.** Electronic zero that balances the compensation bridge with zero RF input. To zero meter during operation, close the switch momentarily. Be sure that RF power is not applied to the thermistor mount when the FINE ZERO switch is depressed.
5. **Meter.** Indicates power input to thermistor mount in milliwatts and dBm. To use the dBm scale, note the value in dBm of the range in use, and subtract from it the reading on the meter dBm scale.
6. **Mechanical Meter Zero.** Sets meter suspension so that meter indicates zero. To adjust the zero:
  - a. Turn POWER switch off.
  - b. Turn the adjustment screw clockwise until the indicator falls below zero and comes back up to zero again.
  - c. Turn the adjustment very slightly counter-clockwise to free up the mechanism from the adjusting peg.
7. **CALIBRATION FACTOR.** Amplifier gain compensation selector. Set to correspond to the calibration factor printed on the thermistor mount body. See Paragraph 3-23 for more information.
8. **MOUNT RESISTANCE.** Selects resistance equal to that of mount in use to balance bridges. Table 1-2 lists Hewlett-Packard thermistor mounts and resistances. Set with meter power OFF, when mount is initially connected to the meter.
9. **Thermistor Mount Cable Connector.** Input connector for 5-1/2 foot cable that connects to the 478A, 8478B, or 486A Thermistor Mounts.

Figure 3-2. Front Panel Controls, Connectors and Indicators (Sheet 2 of 2)

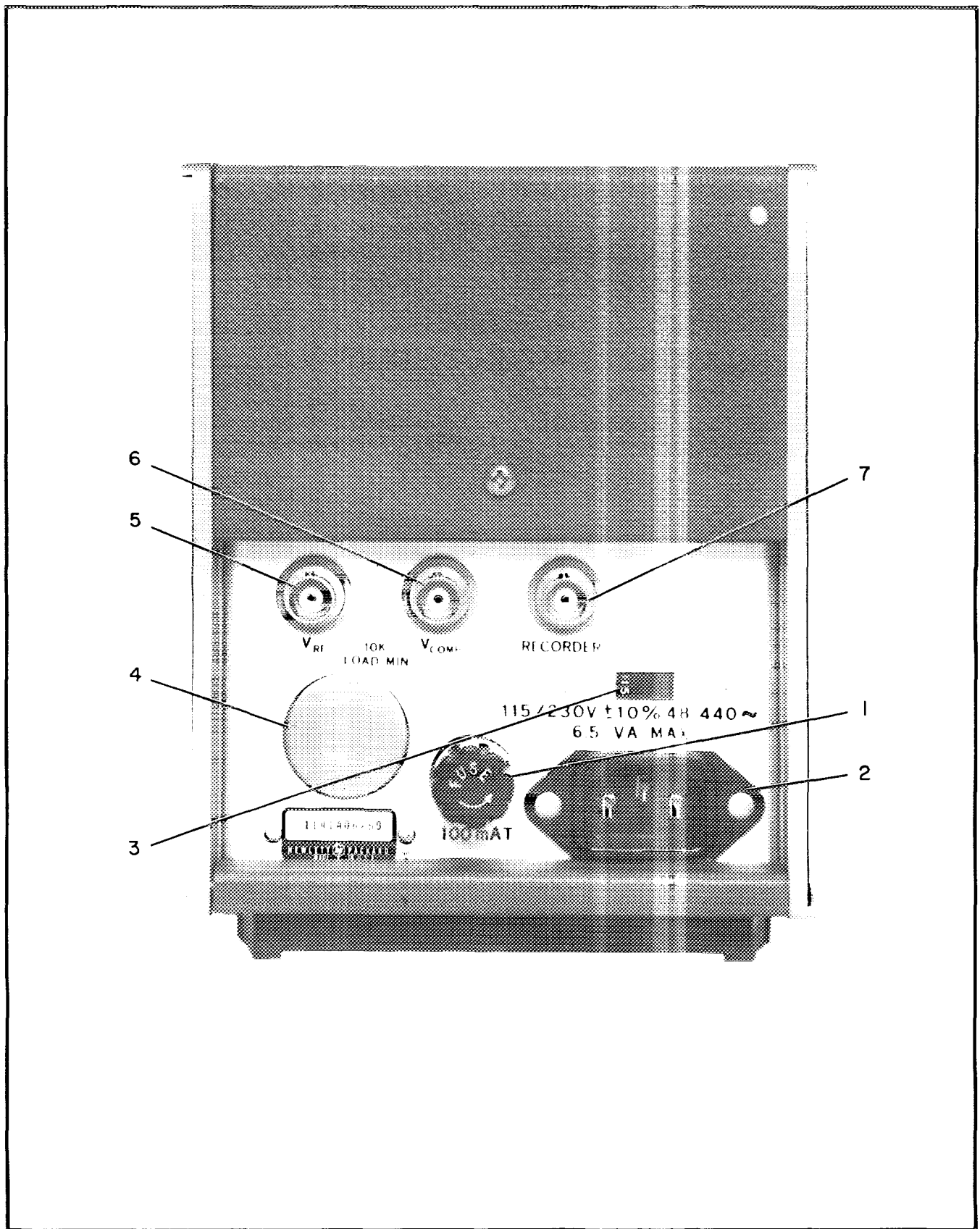

Figure 3-3. Rear Panel Controls and Connectors (Sheet 1 of 2)

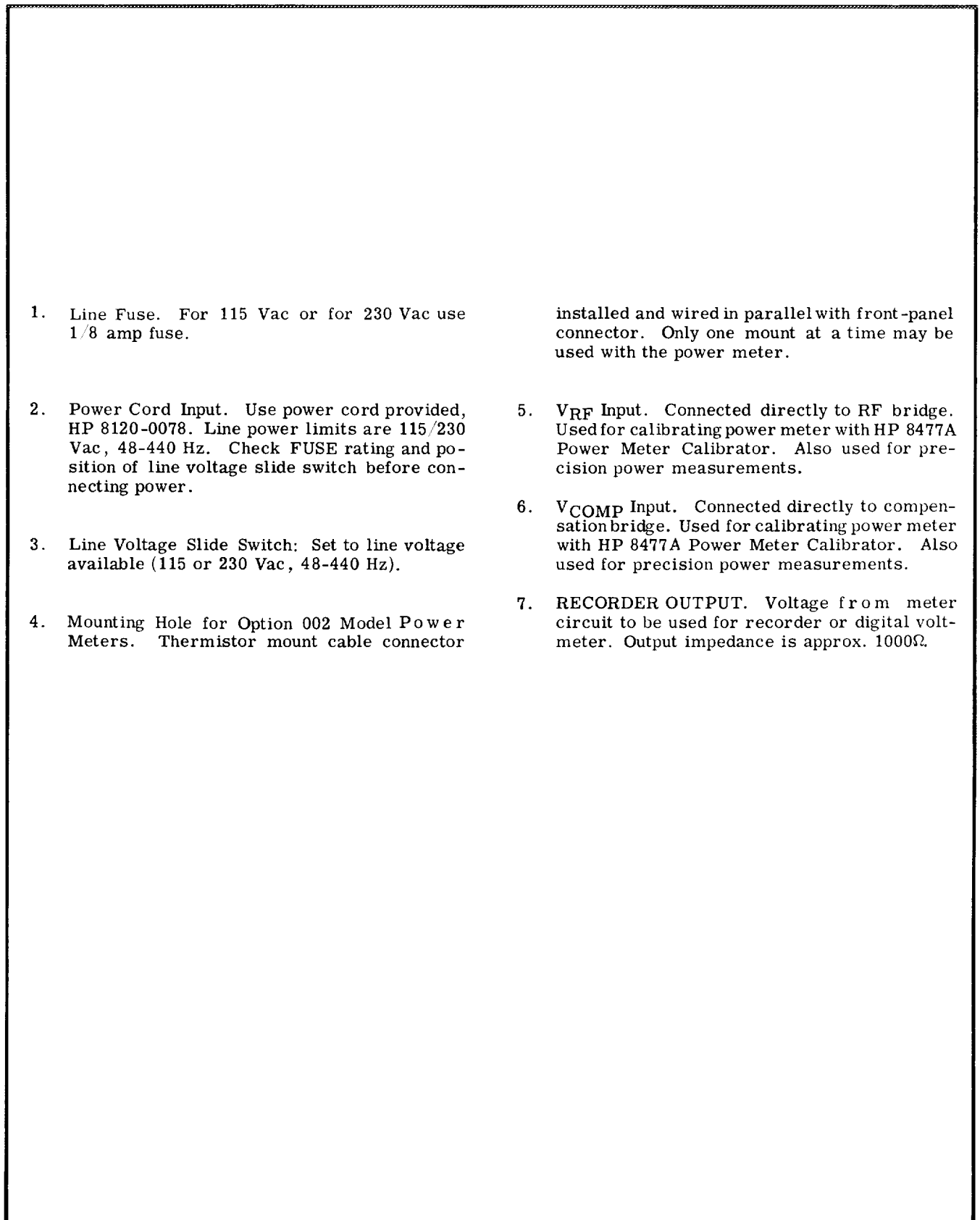

Figure 3-3. Rear Panel Controls and Connectors (Sheet 2 of 2)

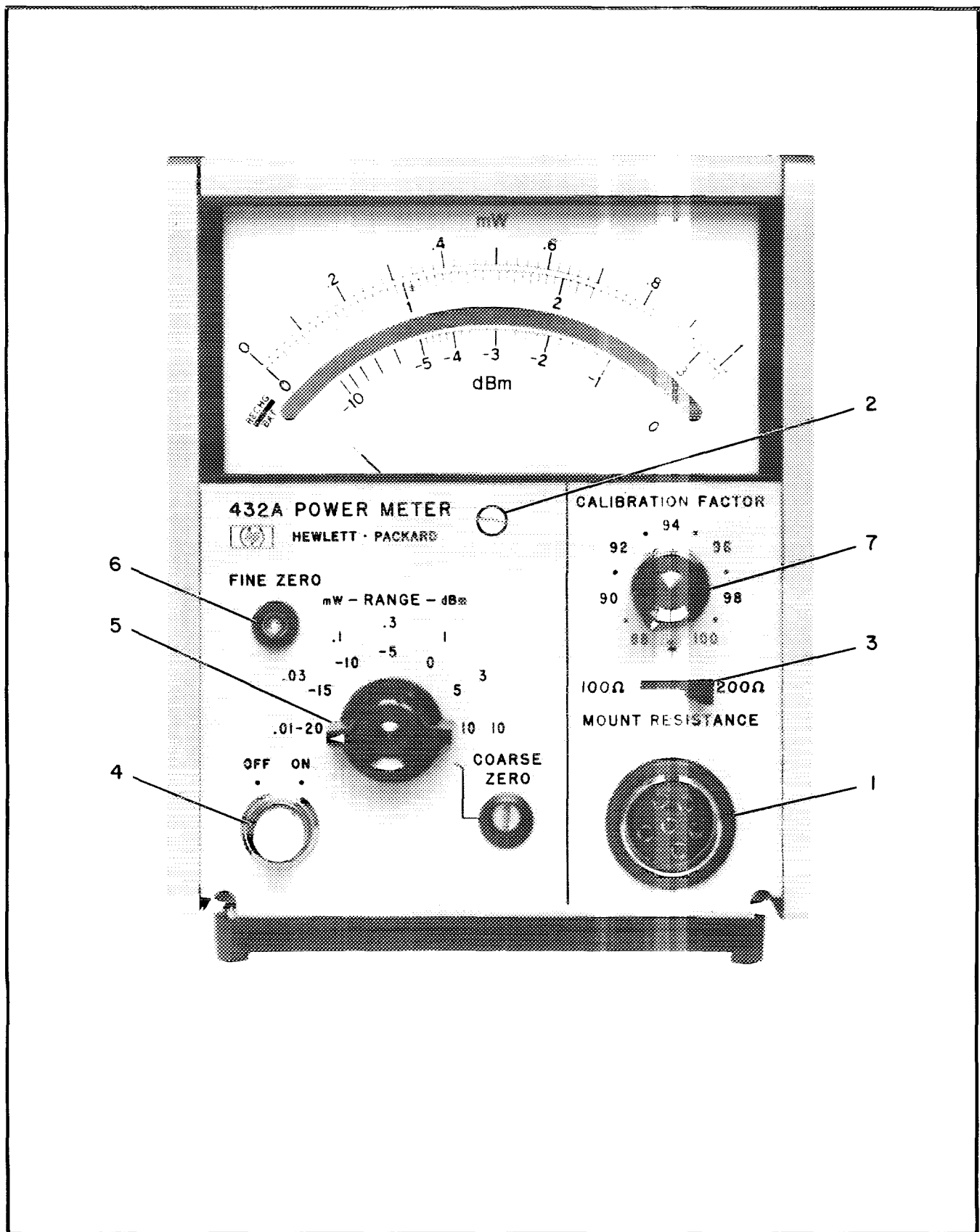

Figure 3-4. Turn On and Zeroing Procedure (Sheet 1 of 2)



1. Connect the thermistor mount and cable to THERMISTOR MOUNT connector. Refer to Table 1-2 for recommended thermistor mounts and their frequency ranges.
2. Meter Mechanical Zero:
  - a. With the instrument turned off, rotate the meter adjustment screw clockwise until the pointer approaches the zero mark from the left.
  - b. Continue the clockwise rotation until the pointer coincides with the zero mark. If the pointer overshoots, continue rotating the adjustment screw clockwise until the pointer once again approaches the zero mark from the left.
  - c. Rotate the adjustment screw about three degrees counterclockwise to disengage screw adjustment from the meter suspension.
3. Set the MOUNT RES switch to correspond to the operating resistance of thermistor mount used.
4. Turn the 432A POWER switch ON. For battery operation, the AC LINE indicator does not turn on.
5. Set the RANGE selector to COARSE ZERO and then zero the meter with the COARSE ZERO screwdriver adjustment.
 

Note

The power meter should be zeroed with the RF power source turned off, or the mount disconnected from the source.
6. Set the range selector to the 0.01 mW range; then depress the FINE ZERO switch until the meter indicates zero.
 

Note

Range-to-range zero carryover is less than  $\pm 0.5\%$  if the meter zero has been adjusted (step 2 above), and the instrument has been properly zero-set on the sensitive range. For maximum accuracy, zero-set the power meter on the range to be used.
7. Set CALIB FACTOR switch to correspond to Calibration Factor imprinted on HP thermistor mount label.
8. Apply RF power to the thermistor mount. Power is indicated on the meter directly in mW or dBm.

Figure 3-4. Turn On and Zeroing Procedure

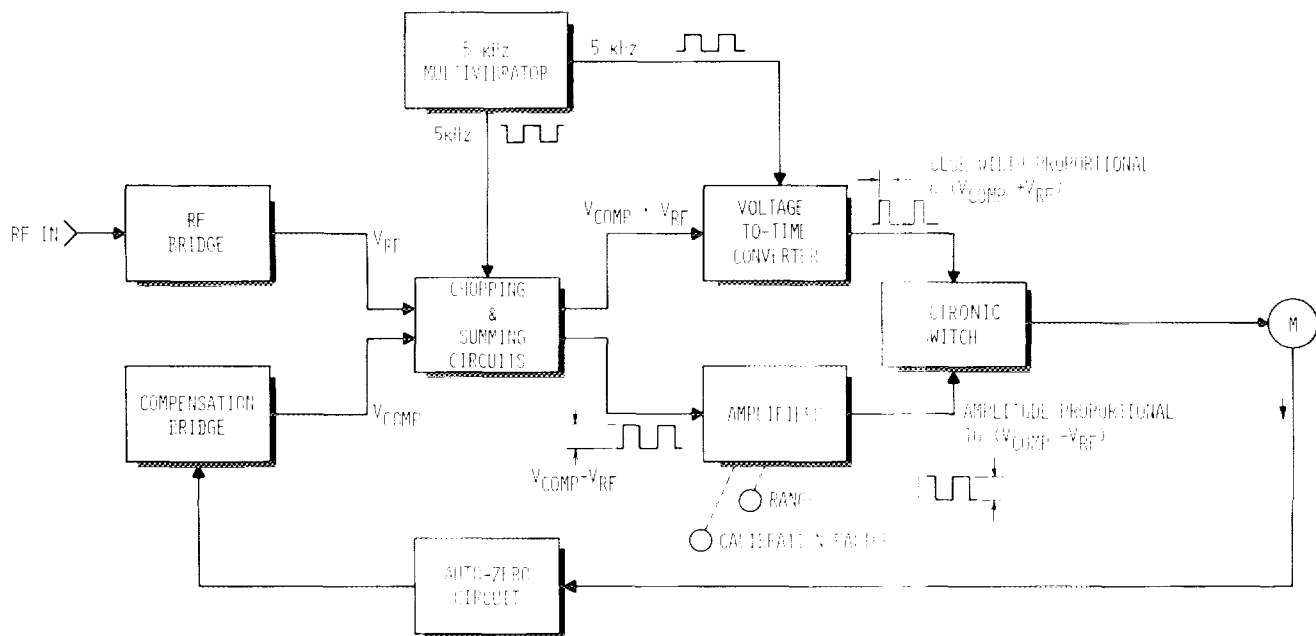

Figure 4-1. Simplified 432A Block Diagram

## SECTION IV

### PRINCIPLES OF OPERATION

#### 4-1. SIMPLIFIED DESCRIPTION

4-2. The HP 432A Power Meter consists of two major sections: the bridge and meter logic assemblies. The instrument also contains an auto zero circuit which provides for automatic zeroing on any range. A simplified block diagram of the HP 432A is shown in Figure 4-1.

4-3. The bridge section contains circuits which form two self-balancing bridge circuits when a suitable thermistor mount is connected to the 432A. Each bridge is automatically brought to balance by the action of a high gain dc amplifier feeding power to the top of the bridge. The voltage at the top of the RF bridge,  $V_{RF}$  is responsive to both input RF power and ambient temperature changes. The voltage at the top of the compensation bridge,  $V_{COMP}$  is responsive only to ambient temperature changes. Knowing  $V_{RF}$  and  $V_{COMP}$ , the RF power can be calculated.

4-4. The meter logic section processes  $V_{RF}$  and  $V_{COMP}$  to produce a meter current proportional to RF power. The sum ( $V_{RF} + V_{COMP}$ ) controls the width of 5 kHz pulses. The difference ( $V_{COMP} - V_{RF}$ ) is chopped, amplified and fed to an electronic switch actuated by the controlled width pulses. Therefore, the meter current is pulses of variable height and width with the meter indicating the average current. (This process produces a meter current proportional to ( $V_{RF} + V_{COMP}$ ) ( $V_{RF} - V_{COMP}$ ). Paragraph 4-10 explains why this is necessary.

#### 4-5. FUNCTIONAL BLOCK DIAGRAM

4-6. A functional block diagram of the 432A power meter is shown in Figure 4-2. The instrument comprises two major assemblies: bridge assembly A1 and meter logic assembly A2. Auto zero circuit A1A1, which provides for automatic zeroing of the instrument, is included as part of logic assembly A1.

4-7. The thermistor bridges are biased with direct current from the bridge amplifiers. Each bridge amplifier supplies enough heating current to bring the thermistor resistance to 100 or 200 ohms, depending upon the setting of the MOUNT RESISTANCE switch on the 432A. If one of the thermistor bridges is unbalanced due to incorrect thermistor resistance, an error voltage occurs and is amplified by the bridge amplifier. The error voltage is applied to the top of the bridge and changes the power dissipation of the negative temperature coefficient thermistor. The change of power dissipation causes the resistance to the thermistor to change in the direction required to balance the bridge. Application of RF power to the RF bridge heats the thermistor and lowers its resistance. The bridge circuit responds by reducing the dc voltage applied to the top of the bridge thus maintaining bridge balance.

4-8. If ambient temperature causes changes in the thermistor resistance, the bridge circuits respond by applying an error voltage to the bridges to maintain bridge balance. The voltage at the top of the RF bridge is dependent upon both ambient temperature and the RF input. The voltage at the top of the compensation bridge is dependent upon the ambient temperature only. The power meter reading is brought to zero with no applied RF power by making  $V_{COMP}$  equal to  $V_{RF}$  so ( $V_{COMP} - V_{RF}$ ) equals zero. Since ambient temperature causes both thermistors to respond similarly, there will be no net difference between the amplifier output voltages. Therefore, any difference in output voltages from the bridges is now due to RF power absorbed by the thermistor mount.

4-9. The RF bridge voltage,  $V_{RF}$ , and the compensation bridge voltage,  $V_{COMP}$ , contain the "RF power" information. To provide a meter reading proportional to RF power the dc voltages ( $V_{RF}$ ,  $V_{COMP}$ ) must be further processed by the meter logic circuits.

4-10. The required processing is derived as follows:  $P_o$  is absorbed power needed by the RF thermistor to bring its resistance to R ohms (100 or 200 ohms).  $P_o$  consists of two components: RF power and dc power supplied by the 432A. The self-balancing action of the bridge circuit automatically adjusts the dc power so that the total power in the thermistor is  $P_o$ . This dc power is related to the voltage  $V_{RF}$  at the top of the bridge by  $(V_{RF}/2)^2/R$ . Thus

$$\begin{aligned} P_o &= \text{RF power} + \text{DC power} \\ &= \text{RF power} + \frac{V_{RF}^2}{4R} \end{aligned}$$

4-11. RF power can be determined by measuring  $V_{RF}$  with and without applied RF power and then doing some arithmetic. But this power measuring scheme is neither convenient nor temperature compensated (since  $P_o$  changes with temperature). The 432A introduces another thermistor bridge circuit exposed to the same ambient temperature but not RF power. This circuit includes adjustments (COARSE and FINE ZERO) so that the dc voltage  $V_{COMP}$  at the top of its bridge can be set equal to  $V_{RF}$ . Assuming matched RF and compensation thermistors,  $V_{RF0}$  (with no RF power) and  $V_{COMP}$  remain equal with ambient temperature fluctuation. They differ only when the RF power to be measured is applied to the RF thermistor. Thus, we have

$$V_{COMP} = V_{RF0} \text{ when RF power} = 0$$

and

$$P_o = 0 + \frac{V_{COMP}^2}{4R}$$

Combining equations, we have:

$$\frac{V_{COMP}^2}{4R} = \text{RF power} + \frac{V_{RF}^2}{4R}$$

or

$$\begin{aligned} \text{RF power} &= \frac{V_{COMP}^2 - V_{RF}^2}{4R} \\ &= \frac{1}{4R} (V_{COMP} + V_{RF})(V_{COMP} - V_{RF}) \end{aligned}$$

4-12. Thus an RF power measurement reduces to setting  $V_{COMP} = V_{RF0}$  (with zero RF power) initially, measuring  $V_{COMP}$  and  $V_{RF}$ , and computing with the above formula. The 432A carries out the computation by forming the indicated sum and difference, performing the multiplication and displaying the result on a meter.

4-13. The meter logic circuits change the two dc voltages to two pulse signals which contain all the RF power information. One of the signals will be a square wave whose amplitude is proportional to  $V_{COMP} - V_{RF}$ . The other signal will have a pulse width proportional to  $V_{COMP} + V_{RF}$ .

4-14. The  $V_{COMP} - V_{RF}$  signal is obtained by taking the dc voltage outputs from the A1 assembly and applying them to a chopper circuit. This chopper circuit is driven by a 5-kHz multivibrator. The output of the chopper is a square wave signal whose amplitude is proportional to  $V_{COMP} - V_{RF}$ . The output of the chopper is coupled to the range amplifier and then to the calibration factor amplifier. The amplification that the signal receives in these two amplifiers depends upon the setting of the RANGE switch and the CALIBRATION FACTOR switch. The output of the calibration factor amplifier is  $V$ . This current is fed to the electronic switch. A square wave current with amplitude proportional to  $(V_{COMP} - V_{RF})$ .

4-15. The  $V_{COMP} + V_{RF}$  signal is obtained by taking the two dc voltages from A1 assembly through a summing circuit and feeding this voltage to a voltage-to-time converter. The voltage-to-time converter is driven by a 5-kHz multivibrator. The output of the voltage-to-time converter is a signal whose pulse width is proportional to the sum of  $V_{COMP} + V_{RF}$ . This signal controls the electronic switch. From the  $V_{COMP} - V_{RF}$  and  $V_{COMP} + V_{RF}$  inputs, the electronic switch provides a 5-kHz pulse train whose amplitude is proportional to  $V_{COMP} - V_{RF}$  and whose pulse width is proportional to  $V_{COMP} + V_{RF}$ . The pulse width is always 90 msec or less.

4-16. The bias circuit switch and filter provides a zero current reference for the meter circuits. This is accomplished by controlling the dc bias to the first stage of the calibration factor amplifier. This circuit, in effect, restores the dc component to the square wave which has been amplified by ac coupled amplifiers.

4-17. The meter is a 0-1 mA, full-scale meter that has a capacitor across its terminals. The capacitor integrates the output pulses from the current switch so the current into the meter is proportional to the time average of the input pulses. That is, the input current to the meter is proportional to the product of

$$\begin{aligned} &(V_{COMP} + V_{RF})(V_{COMP} - V_{RF}) \\ &= (V_{COMP})^2 - (V_{RF})^2 \end{aligned}$$

4-18. The output from the meter is further filtered so the voltage at the rear panel RECORDER output is suitable for use with either a digital voltmeter or X-Y recorder. The RECORDER output voltage is returned to the compensation bridge through the automatic zero circuit when the FINE ZERO switch is depressed. The automatic zero circuit holds a correction voltage at the input of the compensation bridge amplifier, so when the RF is zero, the meter indication will also be zero.

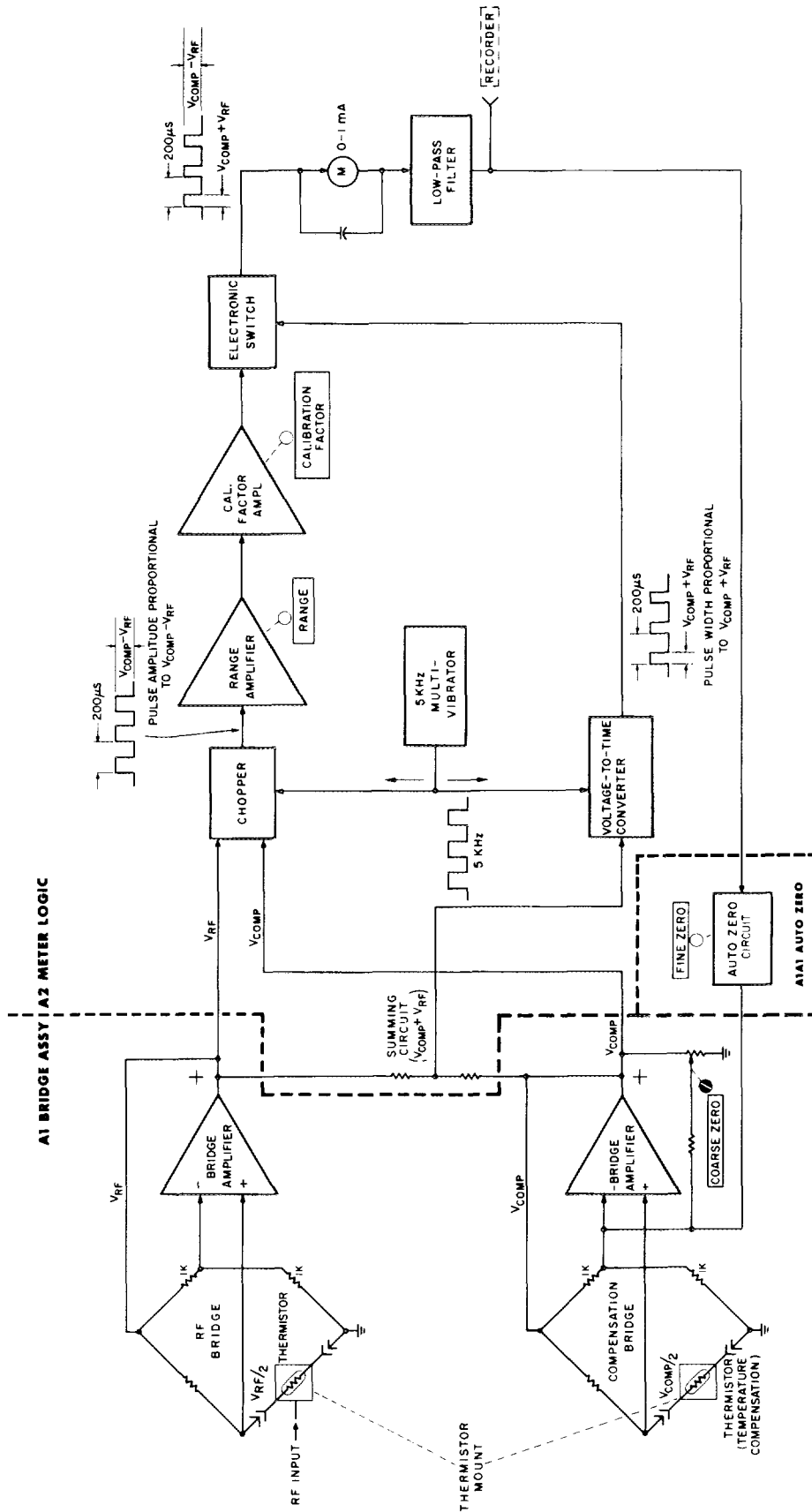

Figure 4-2. Model 432A Block Diagram

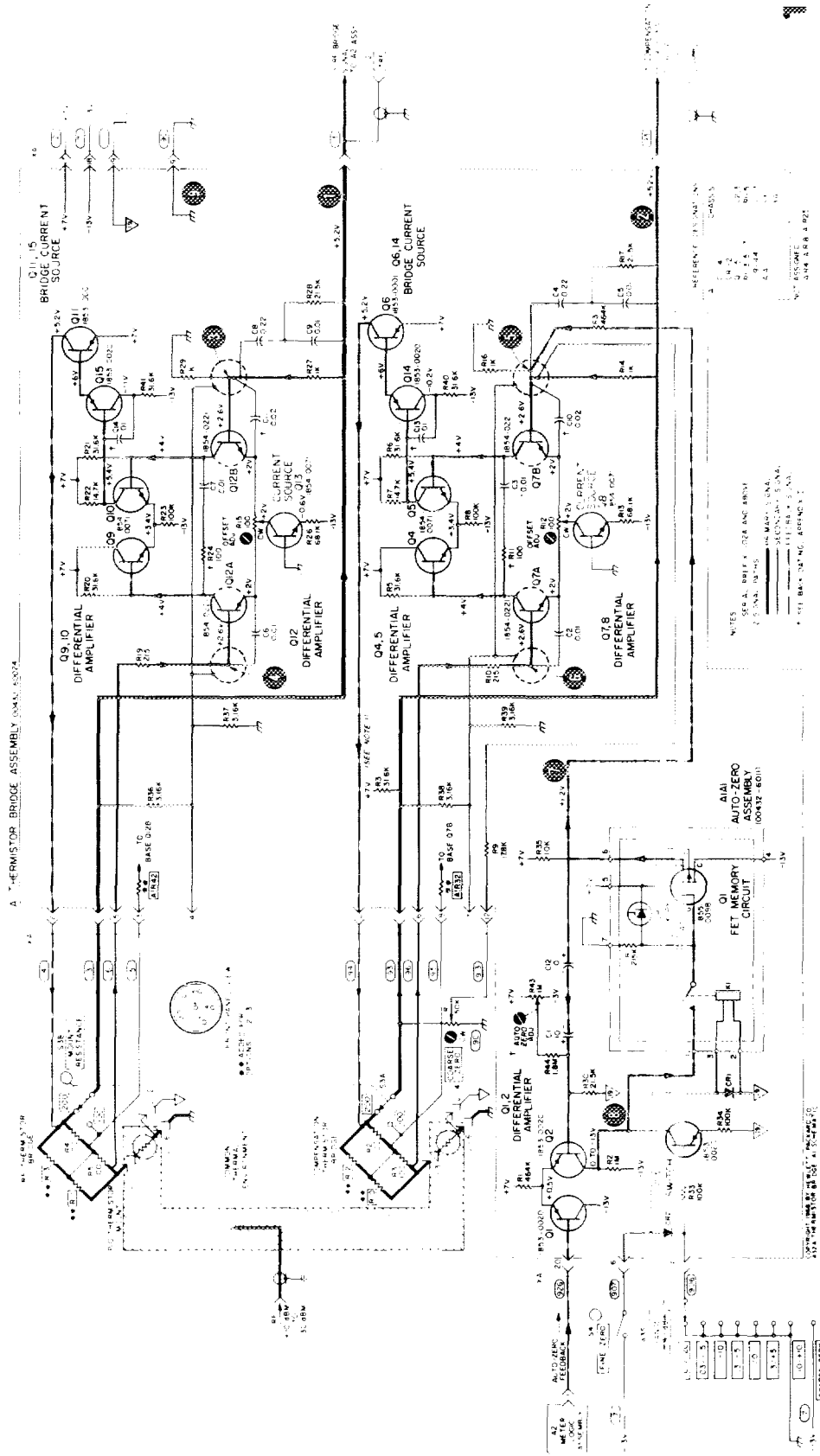

Figure 4-3. Model 432A RF Bridge Taking Schematic (Sheet 1 of 2)

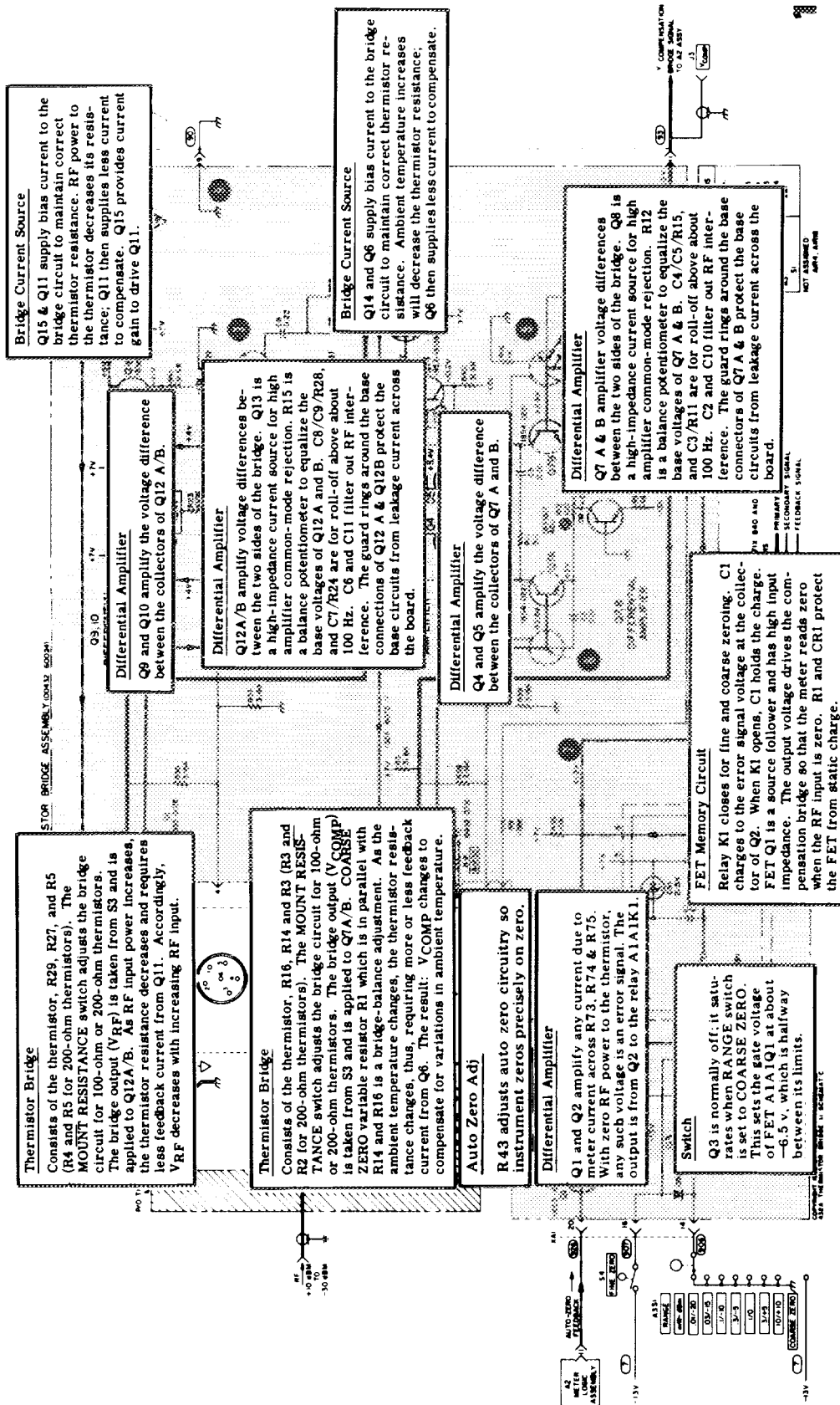
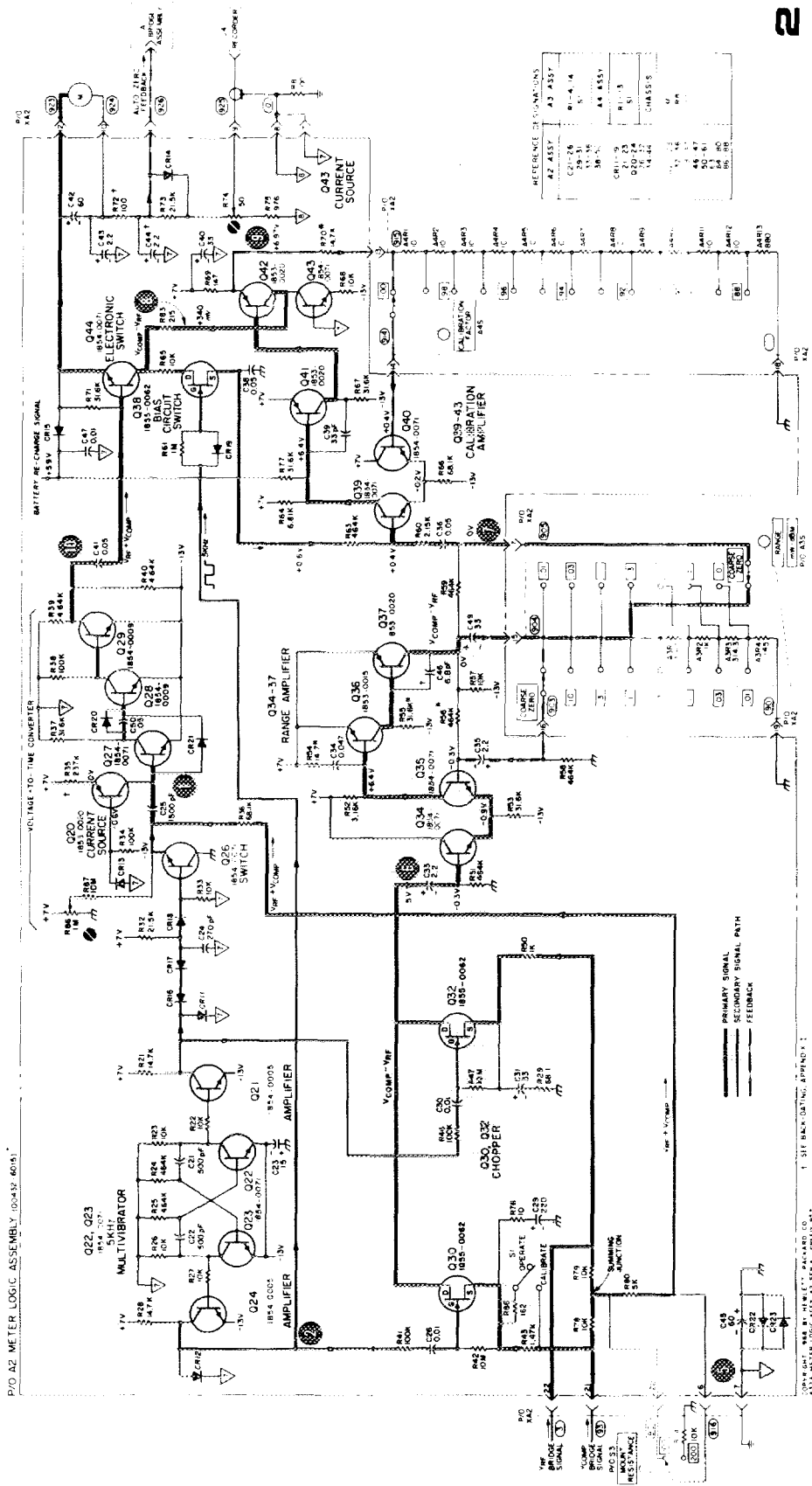

Figure 4-3. Model 432A RF Bridge Talking Schematic (Sheet 2 of 2)



2

Figure 4-4. Model 432A Meter Logic Talking Schematic (Sheet 1 of 2)



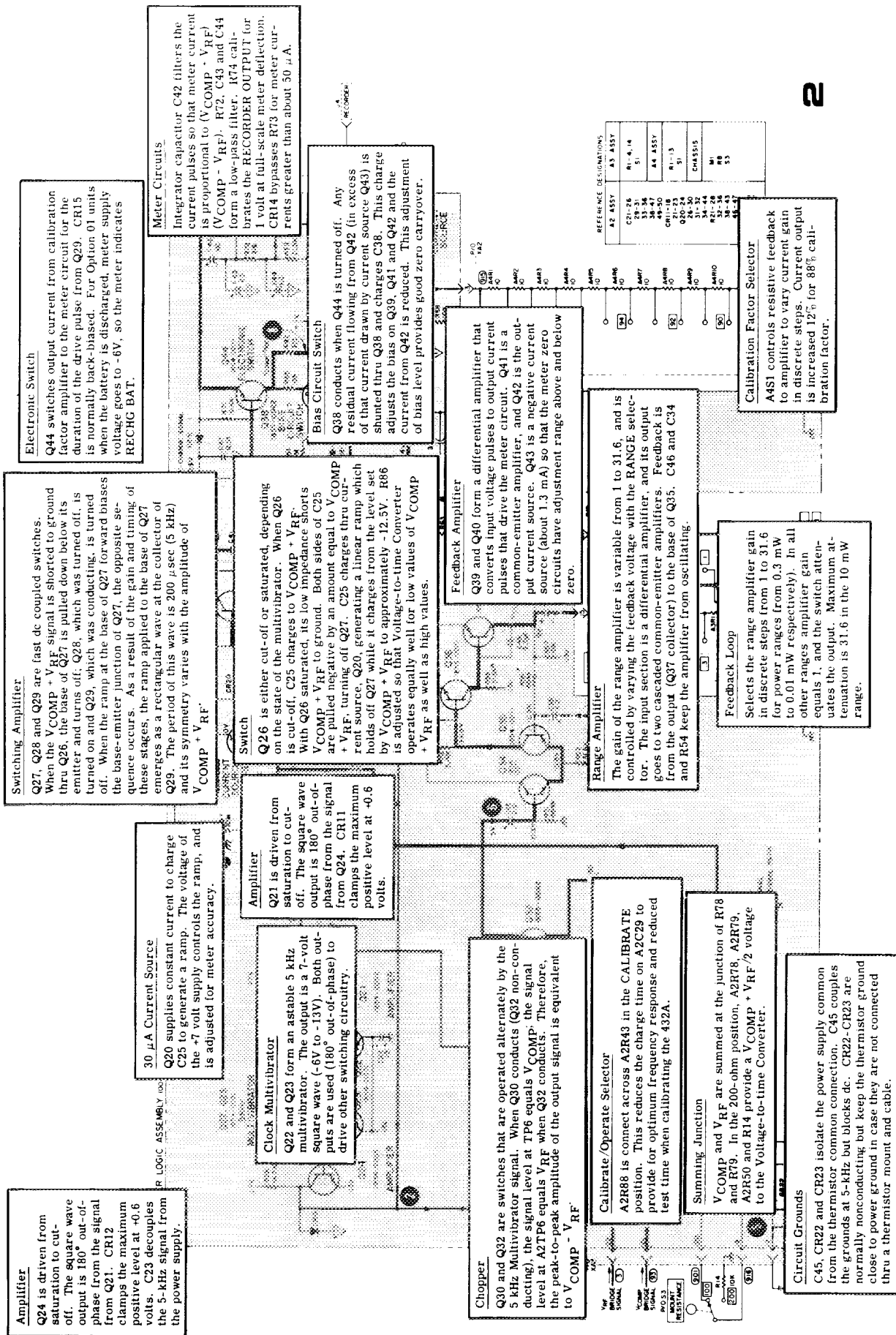
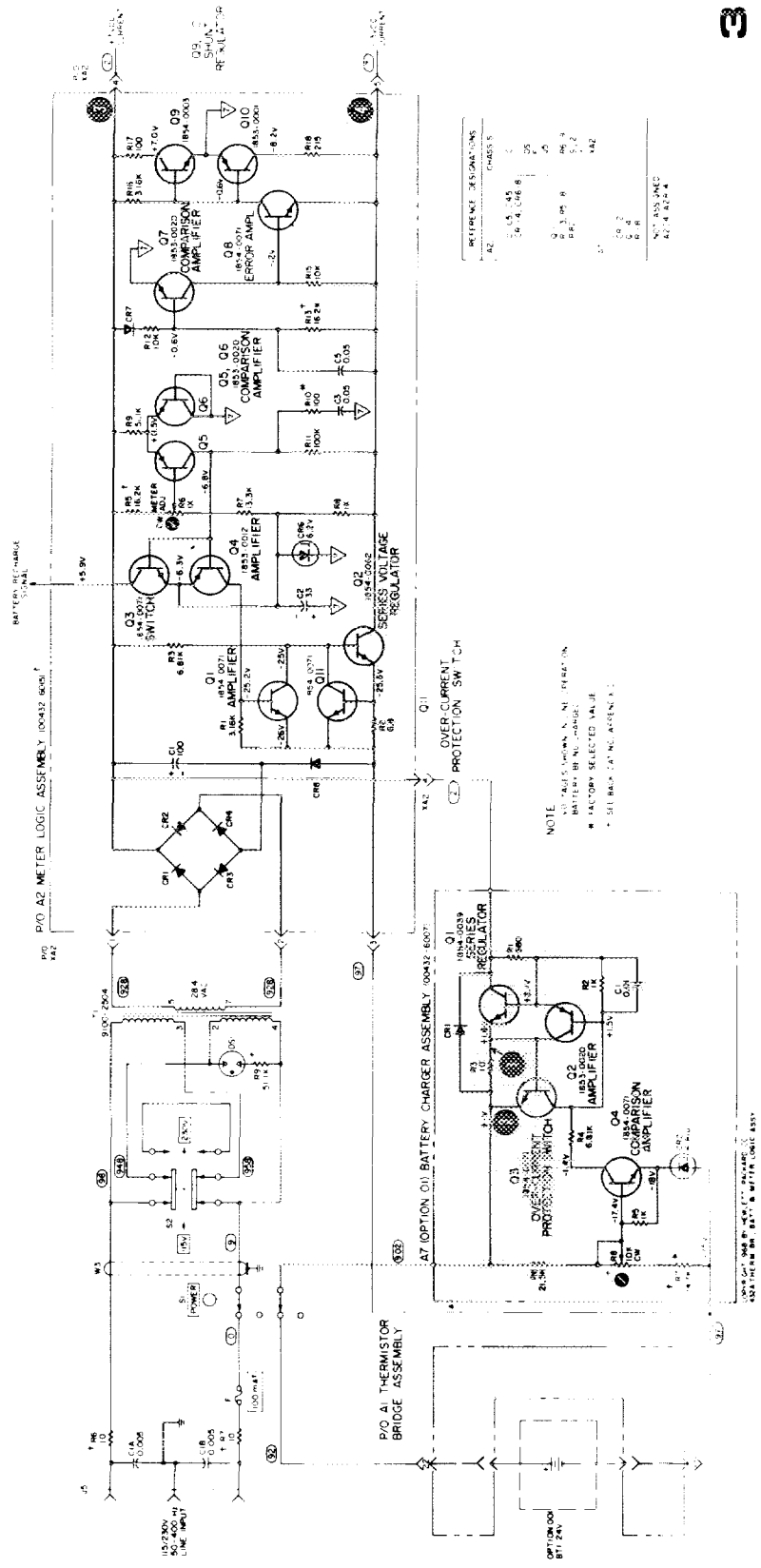
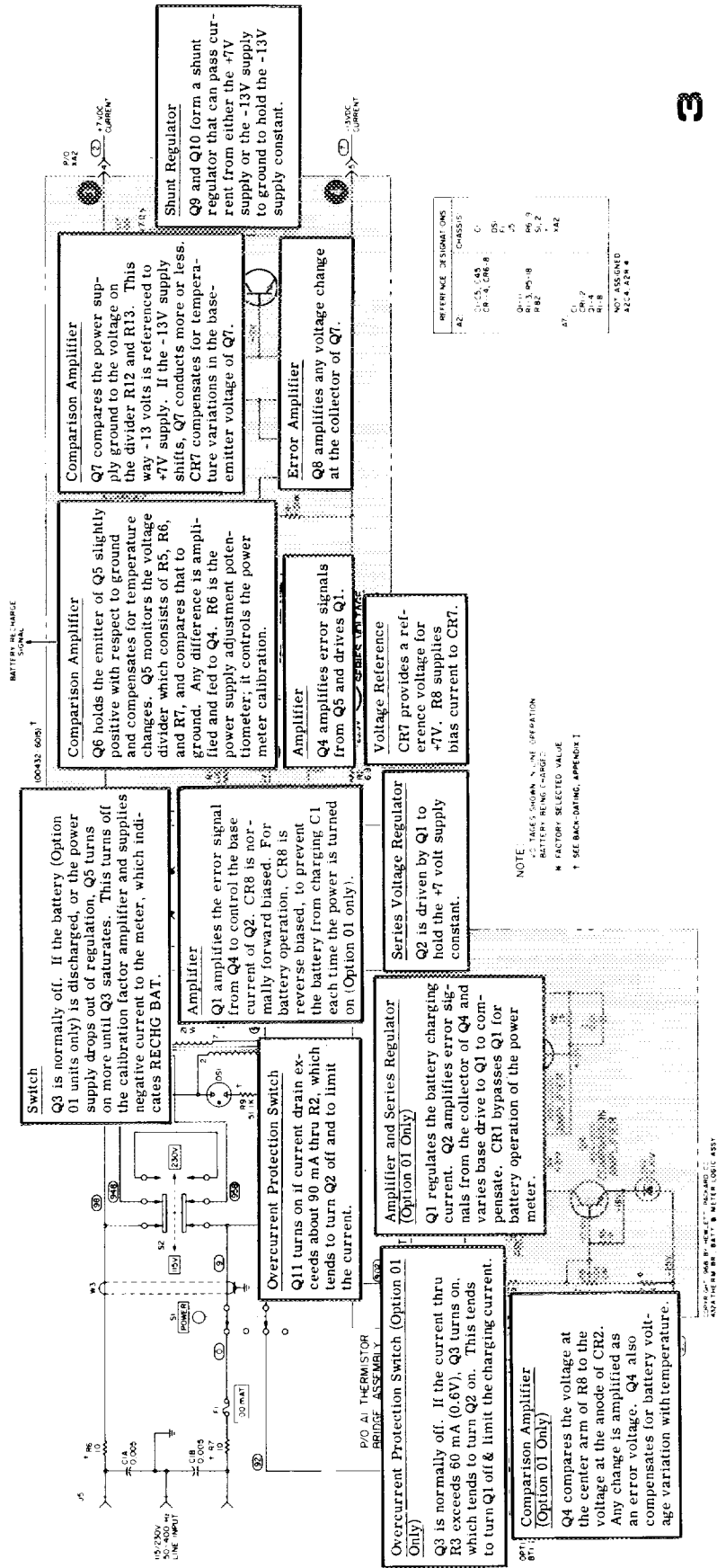

Figure 4-4. Model 432A Meter Logic Talking Schematic (Sheet 2 of 2)



3

Figure 4-5. Model 432A Power Supply Talking Schematic (Sheet 1 of 2)



3

Figure 4-5. Model 432A Power Supply Talking Schematic (Sheet 2 of 2)

Table 5-1. Recommended Test Equipment

Instrument Type	Critical Specifications	Recommended Model
Power Meter Calibrator	Range: 0.1 to 10 mW Accuracy: .1 to 10 mW ranges: 0.2% .01 and .03 mW ranges: 0.5%	HP 8477A
DC Digital Voltmeter	Range: 0.5 to 50 volts dc Accuracy: $\pm 0.05\%$ Input Impedance: 10 megohms, floating Resolution: 4 digits	HP 3440A with 3443A Plug-in Unit
Storage Oscilloscope	Variable Persistence Display Bandwidth: dc to 5 MHz Input Impedance: 1 megohm Sensitivity: 5 mV/division	HP 141A with 1405A and 1420A Plug-in Units
Vertical Plug-in	Bandwidth: 400 kHz Input Impedance: 1 megohm Sensitivity: 1 mV/division	HP 1401A
Cable Assembly (2 required)	RG 58C/U coaxial cable with 2 each BNC male connectors	HP 10503A
Test Lead	Insulated cable terminated with dual banana plug and test clips	HP 11001A
Cable Assembly	Shielded cable with one each BNC and dual banana plug connectors	HP 11000A
Thermistor Mount	Operating Resistance: 100 ohm or 200 ohms	HP 478, 8478
Filter Network		See Figure 5-2
Oscilloscope Probes (2)	Division Ratio: 10:1 $\pm 2\%$ Bandwidth: dc to 30 MHz Rise Time: 5 nsec	HP 10001A
Differential Voltmeter	Accuracy: $\pm 0.005\%$ of reading $+0.0004\%$ of range $\pm 1 \mu V$	HP 740B
Resistor (2)	10K 1%, 1/8 watt	0757-0442

## SECTION V MAINTENANCE

### 5-1. INTRODUCTION.

5-2. This section provides information for performance testing, adjusting, troubleshooting and repairing the 432A Power Meter. Performance tests allow the instrument to be checked for conformance to specifications. If performance is not within specifications, adjust or troubleshoot the instrument.

### 5-3. CONTENT.

#### 5-4. PERFORMANCE TESTS.

5-5. The procedures test power meter performance for incoming inspection, periodic evaluation, calibration and troubleshooting. Specifications in Table 1-1 are the performance standards. If the power meter fails to meet any of the performance test specifications, refer to the troubleshooting diagrams.

#### 5-6. ADJUSTMENTS.

5-7. Procedures describe the adjustments necessary to calibrate the power meter. Adjust the power meter only when it is determined that the meter is out of adjustment and not malfunctioning due to a circuit failure.

5-8. To avoid errors due to possible ground loop currents, isolate the power meter from ground used for other auxiliary equipment. A power plug adapter that removes the ground connection at the line outlet can be used to isolate the power meter.

5-9. Several circuit components are factory-selected to meet specific circuit requirements. The factory selected parts are indicated on the schematic diagrams.

#### 5-10. TEST EQUIPMENT.

5-11. Instruments and accessories required for adjusting and testing the power meter are listed and briefly described in Table 5-1. Instruments used to maintain the instrument must meet or exceed the specifications given.

#### 5-12. SERVICE INFORMATION.

5-13. Service information in the form of troubleshooting, waveforms, schematics and component locations are given in Section VII. Also, an overall system block diagram is included which contains keyed numbers corresponding to the test points.

### 5-14. 432A PERFORMANCE TESTS WITH 8477A CALIBRATOR

#### 5-15. INITIAL SET-UP.

a. Connect the 8477A outputs to the 432A inputs as shown in Figure 5-1. Use appropriate test equipment as listed in Table 5-1.

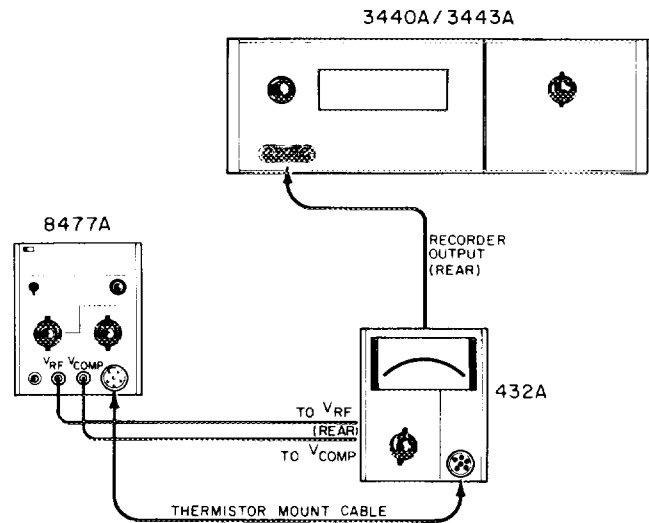

Figure 5-1. Check and Adjustment Test Set-Up

b. If necessary, mechanically zero the meter movement as follows:

- (1) With instrument turned off, rotate meter adjustment screw clockwise until pointer approaches zero mark from the left.
- (2) Continue rotating clockwise until pointer coincides with zero mark. If pointer overshoots, continue rotating adjustment screw clockwise until pointer once again approaches zero mark from the left.
- (3) Rotate adjustment screw about three degrees counterclockwise to disengage screw adjustment from meter suspension.

#### 5-16. METER ACCURACY TEST.

a. Set the 8477A Calibrator controls as follows:

POWER (MW) .....	0.01 mW
FUNCTION .....	200Ω
ZERO/TEST .....	ZERO

b. Set the 432A controls as follows:

A2S1 (on Meter Logic Assy) .....	CALIBRATE
MOUNT RESISTANCE .....	200Ω
RANGE .....	0.1 mW
POWER .....	ON
CALIBRATION FACTOR .....	100%

c. Adjust 8477A ZERO knob for 0 volts  $\pm 2$  mV indication on the DVM.

Table 5-2. Meter Accuracy Test

432A Range (mW)	8477A Range (mW)	Digital Voltmeter Indication (millivolts $\pm 10$ mV)	Indication (Full scale $\pm 1/2$ Div.)
.01	.01	1000	1
.03	.03	948.8	3
.1	.1	1000	1
.3	.3	948.8	3
1	1	1000	1
3	3	948.8	3
10	10	1000	1

d. Set the 8477A controls as follows:

POWER (MW) . . . . . 0.01 mW  
ZERO /TEST . . . . . TEST

e. The digital voltmeter should indicate 1000  $\pm 10$  millivolts.

f. The 432A meter should indicate full scale  $\pm 1/2$  division.

g. Repeat steps d through f for each of the other ranges. Set the power meter range selector to the position indicated in Column 1 of Table 5-2 and set the 8477A meter reading selector to the corresponding position indicated in Column 2 of Table 5-2. In each case, the meter indications should correspond to those shown in Table 5-2, Columns 3 and 4.

5-17. CALIBRATION FACTOR TEST.

a. Set 432A controls as follows:

A2S1 (on Meter Logic Assy) . . . . . CALIBRATE  
RANGE . . . . . 0.1 mW  
CAL FACTOR . . . . . 88%  
MOUNT RESISTANCE . . . . . 200 $\Omega$

b. Set 8477A controls as follows:

FUNCTION . . . . . 200 $\Omega$   
ZERO /TEST Switch . . . . . TEST  
POWER (mW) . . . . . 0.1 mW

c. Set 8477A ZERO control so that the digital voltmeter reads 1000  $\pm 2$  mV.

d. Set the calibration factor selector to 89%.

e. The digital voltmeter should indicate 989  $\pm 10$  millivolts.

f. Repeat steps d and e for each position of the CALIBRATION FACTOR selector. In each case, the digital voltmeter should indicate the voltage shown in the second column of Table 5-3 for the CALIBRATION FACTOR shown in the first column.

Table 5-3. Calibration Factor Test

Calibration Factor Selector Setting (%)	Digital Voltmeter Indication (mV)
88	1000 $\pm 2$
89	989 $\pm 10$
90	978 $\pm 10$
91	967 $\pm 10$
92	957 $\pm 10$
93	946 $\pm 10$
94	935 $\pm 10$
95	926 $\pm 10$
96	916 $\pm 10$
97	907 $\pm 10$
98	897 $\pm 10$
99	889 $\pm 10$
100	880 $\pm 10$

5-18. METER LINEARITY CHECK.

a. Set the 8477A POWER (MW) selector to 1 mW and FUNCTION to 200 $\Omega$ , ZERO /TEST switch to TEST.

b. Set the 432A RANGE selector to 3 mW, MOUNT RESISTANCE to 200 $\Omega$ .

c. The 432A meter should indicate 1 mW  $\pm 1/2$  division.

d. Set the 8477A POWER (MW) selector to 2 mW.

e. The 432A meter should indicate 2 mW  $\pm 1/2$  division.

f. Set the 8477A POWER (MW) selector to 3 mW.

g. The 432A meter should indicate 3 mW  $\pm 1/2$  division.

h. Set A2S1 to OPERATE.

5-19. ZERO CARRYOVER TEST.

a. Disconnect the 432A from the 8477A.

b. Turn the 432A power OFF and connect the thermistor mount cable to a thermistor mount.

c. Set the 432A Power Meter MOUNT RESISTANCE selector to the resistance shown on the thermistor mount.

d. Turn ON the 432A power.

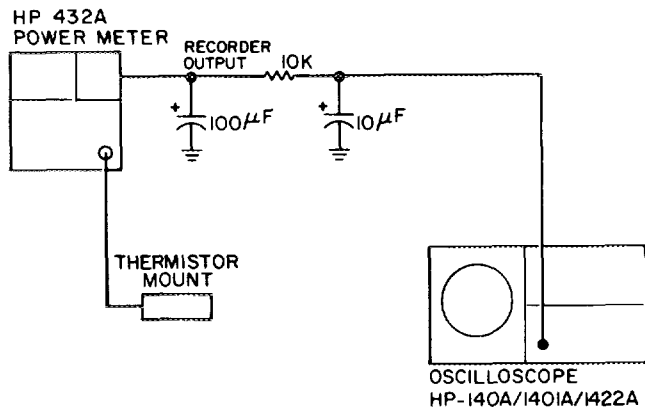

Figure 5-2. Zero Carryover Test Setup

e. Connect 141A through filtering network to rear of 432A as shown in Figure 5-2. Set 141A controls as follows:

INPUT . . . . . DC  
 SENSITIVITY . . . . . 1 mV/cm  
 SWEEP TIME . . . . . 2 sec/cm  
 TRIGGER LEVEL . . . . . max clockwise (free run)

f. Zero the 432A as follows:

- (1) Set the RANGE selector maximum cw to COARSE ZERO.
- (2) Set the COARSE ZERO screwdriver adjust so that the meter indicates zero.
- (3) Set 432A RANGE switch to .01 mW. Depress the FINE ZERO switch. The meter indication should go to zero without overshoot.

g. Rotate the RANGE switch clockwise, one step at a time, while the oscilloscope is sweeping. On each 432A range, the scope trace should be within .01 mW division ( $\pm 5$  mW) from where it was on the .01 mW range.

5-20. FINE ZERO RANGE CHECK.

a. Set the 432A RANGE selector to 0.3 mW. Leave the thermistor mount connected to the cable and the MOUNT RESISTANCE selector set to correspond to the resistance of the mount used.

b. Depress the FINE ZERO switch.

c. Slowly turn the COARSE ZERO screwdriver adjustment counterclockwise until the meter will no longer zero. The FINE zero circuit is at one end of its range.

d. Release FINE ZERO.

e. Set the COARSE ZERO screwdriver adjustment so that the meter indicates full scale on the 0-3 scale (0.3 mW range).

f. Depress FINE ZERO switch (the fine zero circuit is at the other end of its range). Meter should indicate below 2 on the 0-3 scale. Record the indication.

g. Release FINE ZERO.

h. Rotate RANGE switch to COARSE ZERO position. The fine zero circuit is now in the center of its range. The meter reading should be  $1.5 + 1/2$  reading of step f,  $\pm 0.1$  div. on the 0-3 scale.

5-21. 432A CALIBRATION WITHOUT 8477A CALIBRATOR.

5-22. The 432A Power Meter can be calibrated without an 8477A Calibrator using a method similar to the precision power method outlined in Paragraph 3-27.

5-23. A major difference between the two measurements is that external power need not be applied when calibrating the instrument. Normally, in a stable environment, the VCOMP output voltage remains constant, not being affected by external RF power; only the VRF output varies during power measurement. Since the power that the meter indicates is proportional to VCOMP and VRF, we can cause the meter to indicate a power also by holding VRF constant and varying VCOMP. This is easily done on the 432A by turning the COARSE ZERO control. Two calibration procedures are given below. Full scale readings are not possible on the 10 mW RANGE. Full scale readings are possible on the 3 mW RANGE depending on the mount characteristics.

5-24. CALIBRATION PROCEDURE 1.

a. Connect thermistor mount to power meter; let instrument warm up for at least ten minutes.

b. Select range which instrument is to be calibrated on.

Note

Ranges below 0.3 mW require a precise differential voltmeter capable of resolving 1  $\mu$ V. The HP 740B DC Standard  $\Delta$  Voltmeter, which has an accuracy of  $\pm(0.005\%$  of reading + 0.0004% of range  $\pm 1 \mu$ V) is recommended. A digital voltmeter is adequate for the 1.0 mW and higher ranges.

c. Connect Differential Voltmeter (or DVM differentially) between the VCOMP and VRF output jacks on the rear panel. See Figure 3-3 for location of VRF and VCOMP outputs.

d. While pressing the FINE ZERO switch, measure and record  $V_0$ . ( $V_0$  is the difference of the bridge voltages with no power applied.)

e. Turn COARSE ZERO control (on front panel) clockwise to a convenient power, e.g., 9 on the 0 to 10 scale or 2 on the 0 to 3 scale.

f. Differentially measure and record  $V_1$ .  $V_1$  is the difference voltage between VCOMP and VRF with power applied.

**NOTES**



INSTRUMENT SERIAL NO. \_\_\_\_\_

DATE \_\_\_\_\_

**TABLE 5-4. PERFORMANCE TEST CARD**

Data in this test card corresponds to Performance Tests in Paragraphs 5-16 through 5-20.

**TABLE 5-4. PERFORMANCE TEST CARD**

Para. Ref.	Test	Measurement Unit	Min.	Actual	Max.	
5-16	<u>METER ACCURACY</u>					
e	0.01 mW applied; measure RECORDER OUT voltage	mVdc	990	_____	1010	
f	Meter indicates full-scale (0-1 scale)	divisions	-1/2	_____	+1/2	
	<u>Repeat on remaining 432A power ranges:</u>					
e	Power applied: 0.03 mW	mVdc	938.8	_____	958.8	
f	Meter indication (0-3 scale)	divisions	-1/2	_____	+1/2	
e	Power applied: 0.1 mW	mVdc	990	_____	1010	
f	Meter indication (0-1 scale)	divisions	-1/2	_____	+1/2	
e	Power applied: 0.3 mW	mVdc	938.8	_____	958.8	
f	Meter indication (0-3 scale)	divisions	-1/2	_____	+1/2	
e	Power applied: 1 mW	mVdc	990	_____	1010	
f	Meter indication (0-1 scale)	divisions	-1/2	_____	+1/2	
e	Power applied: 3 mW	mVdc	938.8	_____	958.8	
f	Meter indication (0-3 scale)	divisions	-1/2	_____	+1/2	
e	Power applied: 10 mW	mVdc	990	_____	1010	
f	Meter indication (0-1 scale)	divisions	-1/2	_____	+1/2	
5-17	<u>CALIBRATION FACTOR</u>					
i	<u>Calibration Factor (<math>\frac{V}{V}</math>)</u>	<u>DVM Reading (mVdc)</u>				
	88	1000	mVdc	990	_____	1010
	89	989	mVdc	979	_____	999
	90	978	mVdc	968	_____	988
	91	967	mVdc	957	_____	977
	92	957	mVdc	947	_____	967
	93	946	mVdc	936	_____	956
	94	935	mVdc	925	_____	945
	95	926	mVdc	916	_____	936
	96	916	mVdc	906	_____	926
	97	907	mVdc	897	_____	917
	98	897	mVdc	887	_____	907
	99	889	mVdc	879	_____	899
	100	880	mVdc	870	_____	890

**TABLE 5-4. PERFORMANCE TEST CARD**

Para. Ref.	Test	Measurement Unit	Min.	Actual	Max.
5-18	<u>METER LINEARITY</u>				
c	1 mW applied, 3 mW scale: meter indicates 1 mW	divisions	-1/2	_____	+1/2
e	2 mW applied, 3 mW scale: meter indicates 2 mW	divisions	-1/2	_____	+1/2
g	3 mW applied, 3 mW scale: meter indicates 3 mW	divisions	-1/2	_____	+1/2
5-19	<u>ZERO CARRY-OVER</u>				
d	Zero carry-over:				
	<u>Range (mW)</u> <u>Scope Indication</u>				
	.01                                      0 ±5 mVdc	mVdc	-5	_____	+5
	.03                                      0 ±5 mVdc	mVdc	-5	_____	+5
	.1                                        0 ±5 mVdc	mVdc	-5	_____	+5
	.3                                        0 ±5 mVdc	mVdc	-5	_____	+5
	1                                         0 ±5 mVdc	mVdc	-5	_____	+5
	3                                         0 ±5 mVdc	mVdc	-5	_____	+5
	10                                        0 ±5 mVdc	mVdc	-5	_____	+5
5-20	<u>FINE ZERO RANGE</u>				
f	Meter indication on 0-3 scale:	divisions	1.75	_____	2.0
g	Meter indication on 0-3 scale: 1.5 + 1/2 reading of step f, ±0.1 div.	divisions	0.1	_____	0.1

**NOTES**

g. Measure and record  $V_{COMP}$ . Note that the  $V_{COMP}$  jack is isolated from chassis ground; measure from the center conductor of the BNC to the outer conductor.

h. Calculate the power using the following formula\*:

$$P = \frac{1}{4R} \left[ 2 V_{COMP} (V_1 - V_0) - V_1^2 \right] \quad (1)$$

where R is the resistance of the thermistor mount and should be identical to the setting of the MOUNT RESISTANCE switch.

i. If calculated power is different from the value that was set with the COARSE ZERO control, adjust A2R6 so that the meter reads calculated power. If the range of A2R6 is insufficient to set new power, it will be necessary to change the value of A2R70.

j. Set COARSE ZERO so that meter reads 1 on the 0 to 1 scale. Set A2R72 for 1.000V  $\pm 10$  mV at the RECORDER output jack on the rear panel.

5-25. There is a simpler form of the equation that was used to calculate power in step h above. This form ignores  $V_0$ , the small voltage difference between the two bridges with no power applied. However,  $V_0$  becomes negligible on the higher ranges, that is, 1 mV and above, and can be ignored with little decrease in accuracy. The simpler form is as follows:

$$P = \frac{1}{4R} (V_C - V_{RF}) (V_C + V_{RF}) \quad (2)$$

#### 5-26. CALIBRATION PROCEDURE 2.

a. Connect thermistor mount to power meter; let instrument warm up for at least ten minutes.

b. Select 1, 3 or 10 mW range.

c. Turn the COARSE ZERO control clockwise to indicate some convenient on-scale reading.

d. Measure  $V_{COMP}$  and record. Note that  $V_{COMP}$  jack is isolated from chassis ground; measure from the center conductor of the BNC to the outer conductor.

e. Measure  $V_{RF}$  and record. Follow measurement procedure in step d.

f. Measure and record  $V_{COMP} - V_{RF}$ . This term must be measured differentially, that is, one side of the DVM connected to  $V_{COMP}$  and the other side connected to  $V_{RF}$ . In this way the full resolution of the DVM can be used.

g. Substituting the measured values into the above formula, calculate the power.

\*This formula is accurate for on-scale readings; however, with no power applied (i.e.,  $V_1 = V_0$ ) it does not solve to  $P = 0$  because of a deleted term  $+ V_0$ . This term can be neglected for any on-scale reading.

h. If calculated power is different from the power set with the COARSE ZERO control, adjust A2R6 so that meter indicates that power. If the range of A2R6 is not great enough to set new power level, the value of A2R70 will have to be changed.

i. Adjust COARSE ZERO so that meter reads 1 on the 0 to 1 scale. Set A2R72 for 1.000V  $\pm 10$  mV at the RECORDER output jack on the rear panel.

### 5-27. COVER REMOVAL AND REPLACEMENT.

5-28. The side covers can be removed and replaced independently of the top and bottom covers. Each side cover is held in place by four screws retained by nuts which are fastened to the side frames.

#### 5-29. TOP COVER REMOVAL.

a. At the rear of the instrument, remove the screw that retains the cover.

b. Grasp the cover from the rear, and slide it back 1/2 inch. Then tilt forward edge of the cover upward and lift the cover from the instrument.

#### 5-30. TOP COVER REPLACEMENT.

a. Rest the cover flat on the cast guides projecting inward near the top of each side frame.

b. Slide the cover forward, allowing its forward edge to enter the groove in the front panel.

c. Replace the cover retaining screw.

#### 5-31. BOTTOM COVER REMOVAL.

a. Remove the retaining screw at the rear of the cover.

b. Swing the tilt stand out to free the cover.

c. Slide the cover rearward far enough to free the forward edge.

d. Tilt the forward edge of the cover upward and lift the cover from the instrument.

#### 5-32. BOTTOM COVER REPLACEMENT.

a. Set the tilt stand out of the way of the cover.

b. Rest the bottom cover flat on the case guides projecting inward near the bottom of each side frame.

c. Slide the cover forward on the guides so that the formed portion at the rear of the cover slides over the two short projections at the rear corner of each side frame.

d. Replace the retaining screw.

**5-33. ADJUSTMENT PROCEDURES.**

**5-34. INITIAL SETUP.**

- a. Remove the power meter side panels.
- b. Connect the equipment as shown in Figure 5-1. Refer to Table 5-1 for equipment specifications.

**5-35. MECHANICAL METER ADJUSTMENT.**

a. When the meter is properly zero-set, the pointer rests over the zero mark on the meter scale when the instrument is:

- (1) at normal operating temperature
- (2) in its normal operating position
- (3) turned off.

b. Set the pointer as follows to obtain best accuracy and mechanical stability:

- (1) Turn instrument off.
- (2) Rotate the meter mechanical adjustment screw clockwise until the meter is to the left of zero and moving up the scale toward zero. Stop when the pointer is exactly over the zero mark. If the pointer overshoots, repeat step 2.
- (3) When the pointer is exactly on zero, rotate the adjustment screw approximately three degrees counterclockwise. This frees the adjustment screw from the meter suspension. If the pointer moves during this step, repeat steps 2 and 3.

**5-36. BRIDGE AMPLIFIER TESTS.**

a. Connect equipment as shown in Figure 5-3.

b. Compensation Bridge.

- (1) Connect 3440A/3443A between A1TP5 and A1TP6 (using 10K isolation resistors).
- (2) Make the following settings:

432A

RANGE . . . . . 10 mW  
MOUNT RESISTANCE . . . . . 200Ω

8477A

FUNCTION . . . . . SET

- (3) Adjust A1R12 (OFFSET ADJUST) for 0.0 ±0.1 mVdc reading on the digital voltmeter.
- (4) Change 8477A FUNCTION to CHECK. The digital VM reading should not exceed ±0.4 mVdc.

c. RF BRIDGE

- (1) Connect DVM between A1TP3 and A1TP4 using 10K isolation resistors in series with the leads.
- (2) Set 8477A FUNCTION to SET. Adjust A1R15 (OFFSET ADJUST) for DVM reading of 0.0 ±0.1 mVdc.
- (3) Change 8477A FUNCTION to CHECK. The reading should not exceed ±0.4 mVdc.

**Note**

Failure of the instrument to meet the specification of steps b (4) and c (3) above indicates insufficient bridge gain. Refer to Tables 7-3 or 7-4 in the troubleshooting section.

**5-37. METER AND RECORDER OUTPUT CALIBRATION.**

a. Connect the DVM to the 432A RECORDER output.

b. Set 8477A controls as follows:

FUNCTION . . . . . 200Ω  
ZERO TEST . . . . . ZERO  
POWER . . . . . 1 mW

c. Set 432A controls as follows:

A2S1 (on Meter Logic Assy) . . . . . CALIBRATE  
MOUNT RES . . . . . 200Ω  
RANGE . . . . . 1 mW  
CAL FACTOR . . . . . 100%

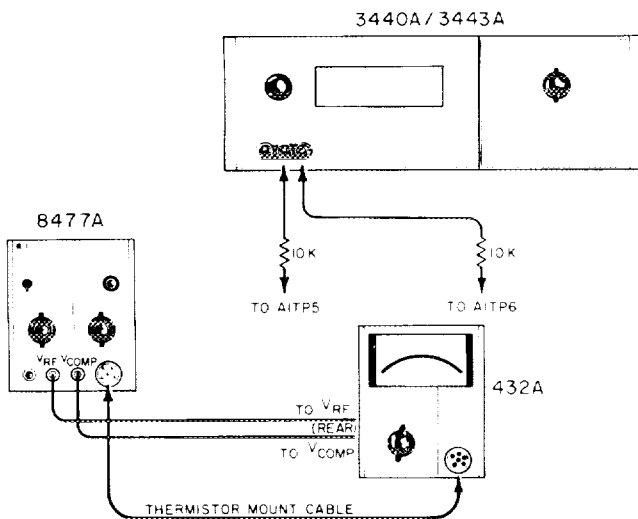

Figure 5-3. Bridge Amplifier Test

- d. Adjust Zero control on 8477A for DVM indication of  $0.000 \pm .001V$ .
- e. ZERO/TEST on 8477A to TEST.
- f. Adjust A2R6 in 432A for 432A meter reading of  $1.0 \text{ mW} \pm .01 \text{ mW}$ .
- g. Adjust A2R74 in 432A for DVM reading of  $1.0V \pm .001V$ .
- h. Change the following settings:

432A RANGE to 10 mW  
8477A POWER (mW) to 10 mW and ZERO/TEST to ZERO.

Note

When switching 432A to 10 mW or switching from 10 mW to any other range, the meter will react slowly for a short period. This is due to time constants in the instrument and is normal.

- i. Check zero and adjust as necessary.
- j. Set ZERO/TEST to TEST and adjust A2R86 for DVM reading of  $1.00 \pm .001V$ .
- k. Return 432A RANGE and 8477A POWER switches to 1 mW and zero as before.
- l. Adjust A2R6 for DVM reading of  $1.000 \pm .001V$ .
- m. Perform the adjustments of steps h through l again until 432A reads  $1 \pm .010V$  (at recorder output) on both 1 mW and 10 mW ranges.
- n. Set A2S1 to OPERATE.
- o. Turn to the beginning of this section; verify that the instrument meets its specifications by completing the PERFORMANCE TESTS.

5-37A. AUTO ZERO ADJUSTMENT, A1R43†

- a. Remove the right side panel.
- b. Connect a mount to the 432A and adjust COARSE ZERO.

- c. Switch RANGE to -20 dBm, push FINE ZERO down and adjust A1R43 for a zero indication on the front panel meter.

- d. Release FINE ZERO and replace the right side panel.

5-38. BATTERY CHARGER ADJUSTMENT (OPTION 01 ONLY).

- a. Remove the power meter top panel.
- b. Connect 432A to ac line power and turn ON.
- c. Set A7R8 fully counterclockwise for maximum battery charge rate.
- d. With the digital voltmeter, measure the voltage between A7TP1 and A7TP2.
- e. Adjust A7R8 for digital voltmeter reading of 0.2 to 0.4 volt (20 to 40 mA through R3) when battery is fully charged.

- f. Disconnect the test equipment and power, and replace the power meter top and side panels.

5-39. BATTERY REMOVAL.

- a. Remove the top cover.
- b. Remove the two Phillips screws on the top rear of the battery cover.
- c. Lift off the battery cover.
- d. Loosen the nuts on the battery binding posts.
- e. Lift out the battery.

**5-40. ISOLATING TROUBLE IN TRANSISTOR CIRCUITS.**

5-41. General. The following information should help determine if a transistor works. There are tests for both in-circuit and out-of-circuit transistors, which help to determine if a particular trouble is due to a faulty transistor or some other component. See Figure 5-2.

Table 5-5. Out-of-Circuit Transistor Resistance Measurements

		Connect Ohmmeter		Measure Resistance (ohms)
		Positive Lead to	Negative Lead to	
PNP Germanium	Small Signal	emitter	base*	200 - 500
		emitter	collector	10K - 100K
	Power	emitter	base*	30 - 50
		emitter	collector	several hundred
NPN Silicon	Small Signal	base	emitter	1K - 3K
		collector	emitter	very high (might read open)
	Power	base	emitter	200 - 1000
		collector	emitter	high, often greater than 1M

\*To test for transistor action, add collector-base short. Measured resistance should decrease.

† See Back-Dating, Appendix I.

DEVICE	SYMBOL	CUT OFF	CONDUCTING
NPN TRANSISTOR	<p>COLLECTOR</p> <p>BASE</p> <p>EMITTER</p>	<p>+20V</p> <p>0V (OR-)</p>	<p>+20V</p> <p>+3V</p> <p>CONTROL CURRENT</p> <p>MAIN CURRENT</p>
PNP TRANSISTOR	<p>COLLECTOR</p> <p>BASE</p> <p>EMITTER</p>	<p>-20V</p> <p>0V (OR+)</p>	<p>-20V</p> <p>-3V</p> <p>CONTROL CURRENT</p> <p>MAIN CURRENT</p>

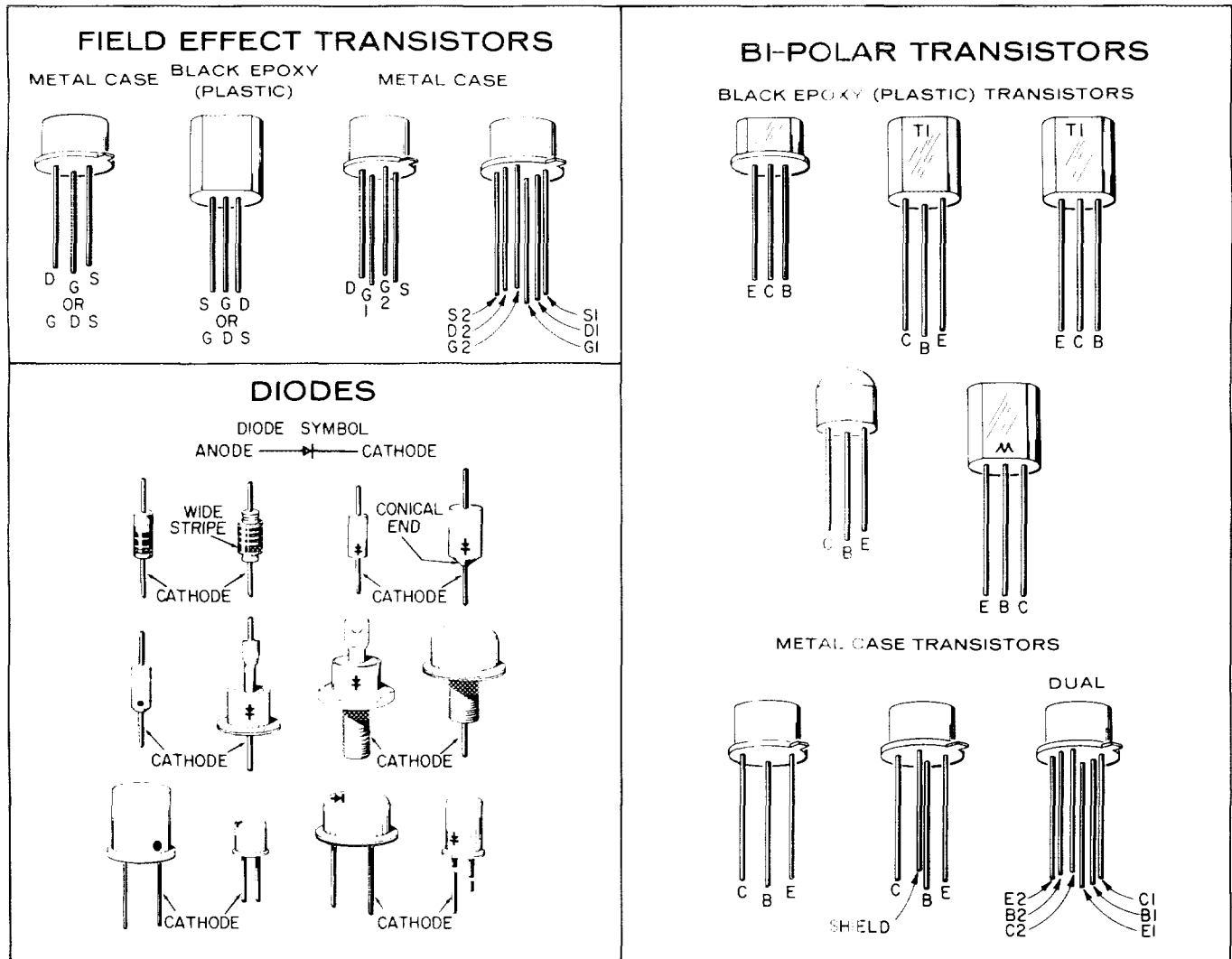

Figure 5-4. Transistor Biasing and Operating Characteristics



Table 5-6. Etched Circuit Soldering Equipment

Item	Use	Specification	Item Recommended
Soldering Tool	Soldering, unsoldering	Wattage rating: 37.5 Tip Temp: 750-800°F Tip Size: 1/8" OD	Ungar #776 handle with Ungar #1237
Soldering Tip, General Purpose	Soldering, unsoldering	Shape: chisel Size: 1/8"	Ungar #PL113
De-soldering Aid	Unsoldering multiconnection components	Suction device to remove molten solder from connection	Soldapult by the Edsyn Company, Arleta, Calif.
Resin (flux) Sol- vent	Remove excess flux from soldered area before appli- cation of protection coating	Must not dissolve etched circuit base board material or conduc- tor bonding agent	Freon, Acetone, Lacquer Thinner, Isopropyl Alco- hol (100% dry)
Solder	Component replacement, cir- cuit board repair or wiring	Resin (flux) core, high tin con- tent (60/40 tin/lead), 18 gauge (SWG) preferred	
Protective Coat- ing	Contamination, corrosion protection after soldering	Good electrical insulation, cor- rosion-preventive properties	Krylon #1320*, Humiseal Protective Coating, Type 1B12 by Columbia Tech- nical Corp., Woodside 77, New York

\*Krylon, Inc., Norristown, Pennsylvania

5-42. In-Circuit Testing. In transistor circuit testing the most important consideration is the transistor base-emitter junction. Like the control grid of a vacuum tube, this is the control point in the transistor.

5-43. To check a transistor, first see if the emitter-base diode is forward-biased by measuring the voltage difference between emitter and base. When using an electronic voltmeter, do not measure directly between emitter and base; there may be sufficient loop current between the voltmeter lead to damage the transistor. Instead, measure each voltage separately with respect to a voltage common point (e. g., chassis).

5-44. If the transistor base-emitter junction is forward-biased, the transistor conducts. If the diode is heavily forward-biased, the transistor saturates. However, if the base-emitter diode is reverse-biased, the transistor is cut off (open). The voltage drop across a forward-biased emitter-base junction varies with transistor collector current. A germanium transistor has a typical base-emitter voltage of 0.2-0.3-volt with 1-10 mA collector current and 0.4-0.5 volt with 10-100 mA collector current. In contrast, base-emitter voltage for silicon transistors is about twice that for germanium types; about 0.5-0.6 volt for low collector current, and about 0.8-0.9 for high collector current.

5-45. If the emitter base-junction is forward-biased, check for amplifier action by short-circuiting base to emitter while observing collector voltage. The

transistor should stop conduction (cut off), which should shift the collector voltage close to the supply voltage. Any difference is due to current leakage through the transistor. In general, the smaller the current, the better the transistor. If collector voltage does not change, the transistor has either an emitter-collector short circuit or emitter-base open circuit.

#### 5-46. OUT-OF-CIRCUIT TESTING.

5-47. The two common causes of transistor failure are internal short- and open-circuits. Remove the transistor from the circuit and use an ohmmeter to measure internal resistance. See Table 5-5 for measurement data.

#### 5-48. **COMPONENT REPLACEMENT IN ETCHED CIRCUITS.**

5-49. General. Etched circuit boards are sensitive to heat and to scratches with sharp objects. This is because the conductors are plated onto the circuit boards and the plating extends through the component mounting holes. Whenever possible, avoid unnecessary component substitution; it can damage the circuit board and adjacent components. See Table 5-6 for recommended tools and materials.

#### 5-50. AXIAL-LEAD COMPONENTS.

5-51. Resistors, tubular capacitors and other axial-lead components can be replaced without unsoldering. Cut the component leads near the body of the defec-

Table 5-7. Safe Ohmmeter Range for Transistor Resistance Measurements

	Safe Range(s)	Open Circuit Voltage	Short Circuit Current	Lead	
				Color	Polarity
HP 412 HP 427A	R x 1 k R x 10 K R x 100 k R x 1M R x 10M	1.0 V 1.0 V 1.0 V 1.0 V 1.0 V	1 mA 100 $\mu$ A 10 $\mu$ A 1 $\mu$ A 0.1 $\mu$ A	Red Black	+ -
HP 410C	R x 1 k R x 10 k R x 100 k R x 1M R x 10M	1.3 V 1.3 V 1.3 V 1.3 V 1.3 V	0.57 mA 57 $\mu$ A 5.7 $\mu$ A 0.5 $\mu$ A 0.05 $\mu$ A	Red Black	+ -
HP 410B	R x 100 R x 1 k R x 10 k R x 100 k R x 1M	1.1 V 1.1 V 1.1 V 1.1 V 1.1 V	1.1 mA 110 $\mu$ A 11 $\mu$ A 1.1 $\mu$ A 0.11 $\mu$ A	Black Red	+ -
Simpson 260	R x 100	1.5 V	1 mA	Red Black	+ -
Simpson 269	R x 1 k	1.5 V	0.82 mA	Black Red	+ -
Triplett 630	R x 100 R x 1 k	1.5 V 1.5 V	3.25 mA 325 $\mu$ A	Varies with Serial Number	
Triplett 310	R x 10 R x 100	1.5 V 1.5 V	750 $\mu$ A 75 $\mu$ A		

tive component, remove the component and straighten the leads left in the board. Wrap leads of the replacement component one turn around the original leads, solder the connection, and clip off the excess lead.

5-52. OTHER COMPONENTS.

5-53. Replace other components as follows:

a. Remove defective component from circuit board. Use a low-power soldering iron because excessive heat may lift a conductor or damage the board.

b. Remove solder from mounting holes with a suction device or a wooden toothpick. DO NOT USE A SHARP METAL OBJECT SUCH AS AN AWL OR TWIST DRILL. SHARP OBJECTS MAY DAMAGE THE PLATED-THROUGH CONDUCTOR.

c. Shape the leads of the replacement component to match the mounting-hole spacing.

d. Insert the component leads in the mounting holes and position it as the original was. DO NOT FORCE LEADS OF REPLACEMENT COMPONENT INTO MOUNTING HOLES. A sharp edge on the lead may damage the plated-through conductor.

e. Solder the component in place and remove excess flux from the soldered areas. Apply a protective coating to prevent contamination and corrosion. See Table 5-6 for recommendations.

**CAUTION**

Most ohmmeters can supply enough current or voltage to damage a transistor. Before using an ohmmeter to measure transistor forward or reverse resistance, check its open-circuit voltage and short-circuit current output ON THE RANGE TO BE USED. Open-circuit voltage must not exceed 1.5 volts and short-circuit current must be less than 3 mA.

## SECTION VI REPLACEABLE PARTS

### 6-1. INTRODUCTION.

6-2. This section contains information for ordering replacement parts. Table 6-1 lists parts in alpha-numerical order of their reference designators provides the following information on each part:

- a. Description.
- b. Manufacturer of the part in a five-digit code; see list of manufacturers in Table 6-2.
- c. Manufacturer's part number.
- d. Total quantity used (TQ column).

### 6-3. ORDERING INFORMATION.

6-4. To obtain replacement parts, address order or inquiry to your local Hewlett-Packard Field Office (see list at rear of this manual for addresses). Identify parts by their Hewlett-Packard stock numbers.

6-5. To obtain a part that is not listed, include:

- a. Instrument model number.
- b. Instrument serial number.
- c. Description of the part.
- d. Function and location of the part.

#### REFERENCE DESIGNATORS

A	= assembly	F	= fuse	MP	= mechanical part	V	= vacuum, tube, neon bulb, photocell, etc.
B	= motor	FL	= filter	P	= plug	VR	= voltage regulator
BT	= battery	IC	= integrated circuit	Q	= transistor	W	= cable
C	= capacitor	J	= jack	R	= resistor	X	= socket
CP	= coupler	K	= relay	RT	= thermistor	Y	= crystal
CR	= diode	L	= inductor	S	= switch	Z	= tuned cavity, network
DL	= delay line	LS	= loud speaker	T	= transformer		
DS	= device signaling (lamp)	M	= meter	TB	= terminal board		
E	= misc electronic part	MK	= microphone	TP	= test point		

#### ABBREVIATIONS

A	= amperes	H	= henries	N/O	= normally open	RMO	= rack mount only
AFC	= automatic frequency control	HDW	= hardware	NPO	= negative positive zero (zero temperature coefficient)	RMS	= root-mean square
AMPL	= amplifier	HEX	= hexagonal			RWV	= reverse working voltage
BFO	= beat frequency oscillator	HG	= mercury	NPN	= negative-positive-negative	S-B	= slow-blow
BE CU	= beryllium copper	HR	= hour(s)	NRFR	= not recommended for field replacement	SCR	= screw
BH	= binder head	HZ	= hertz			SE	= selenium
BP	= bandpass	IF	= intermediate freq	NSR	= not separately replaceable	SECT	= section(s)
BRS	= brass	IMPG	= impregnated			SEMICON	= semiconductor
BWO	= backward wave oscillator	INCD	= incandescent			SI	= silicon
CCW	= counter-clockwise	INCL	= include(s)	OBD	= order by description	SIL	= silver
CER	= ceramic	INS	= insulation(ed)	OH	= oval head	SL	= slide
CMO	= cabinet mount only	INT	= internal	OX	= oxide	SPG	= spring
COEF	= coefficient	K	= kilo = 1000	P	= peak	SPL	= special
COM	= common	LH	= left hand	PC	= printed circuit	SST	= stainless steel
COMP	= composition	LIN	= linear taper	PF	= picofarads = 10 <sup>-12</sup> farads	SR	= split ring
COMPL	= complete	LK WASH	= lock washer	PH BRZ	= phosphor bronze	STL	= steel
CONN	= connector	LOG	= logarithmic taper	PHL	= Phillips	TA	= tantalum
CP	= cadmium plate	LPG	= low pass filter	PIV	= peak inverse voltage	TD	= time delay
CRT	= cathode-ray tube	M	= milli = 10 <sup>-3</sup>	PNP	= positive-negative-positive	TGL	= toggle
CW	= clockwise	MEG	= meg = 10 <sup>6</sup>			THD	= thread
DEPC	= deposited carbon	MET FLM	= metal film	P/O	= part of	TI	= titanium
DR	= drive	MET OX	= metallic oxide	POLY	= polystyrene	TOL	= tolerance
ELECT	= electrolytic	MFR	= manufacturer	PORC	= porcelain	TRIM	= trimmer
ENCAP	= encapsulated	MHZ	= mega hertz	POS	= position(s)	TWT	= traveling wave tube
EXT	= external	MINAT	= miniature	POT	= potentiometer	U	= micro = 10 <sup>-6</sup>
F	= farads	MOM	= momentary	PP	= peak-to-peak	VAR	= variable
FH	= flat head	MTG	= mounting	PT	= point	VDCW	= dc working volts
FIL H	= fillister head	MY	= "mylar"	PWV	= peak working voltage	W/	= with
FXD	= fixed	N	= nano (10 <sup>-9</sup> )	RECT	= rectifier	W	= watts
G	= giga (10 <sup>9</sup> )	N/C	= normally closed	RF	= radio frequency	WIV	= working inverse voltage
GE	= germanium	NE	= neon	RH	= round head or right hand	WW	= wirewound
GL	= glass	NI PL	= nickel plate			W/O	= without
GRD	= ground(ed)						

Table 6-1. Replaceable Parts

Reference Designation	HP Part Number	Qty	Description	Mfr Code	Mfr Part Number
A1	00432-60024	1	BOARD ASSY:BRIDGE	28480	00432-60024
A1A1	00432-6011	1	ASSY:AUTO ZERO	28480	00432-6011
A1C1	0180-0374	2	C:FXD TANT. 10 UF 10% 20VDCW	56289	1500106X902082-DYS
A1C2	0160-2055	8	C:FXD CER 0.01 UF +80-20% 100VDCW	56289	C023F101F103ZS22-CDH
A1C3	0160-2055		C:FXD CER 0.01 UF +80-20% 100VDCW	56289	C023F101F103ZS22-CDH
A1C4	0160-0380	2	C:FXD MY 0.22 UF 10% 200VDCW	28480	0160-0380
A1C5	0160-2055		C:FXD CER 0.01 UF +80-20% 100VDCW	56289	C023F101F103ZS22-CDH
A1C6	0160-2055		C:FXD CER 0.01 UF +80-20% 100VDCW	56289	C023F101F103ZS22-CDH
A1C7	0160-2055		C:FXD CER 0.01 UF +80-20% 100VDCW	56289	C023F101F103ZS22-CDH
A1C8	0160-0380		C:FXD MY 0.22 UF 10% 200VDCW	28480	0160-0380
A1C9	0160-2055		C:FXD CER 0.01 UF +80-20% 100VDCW	56289	C023F101F103ZS22-CDH
A1C10	0160-3459	2	C:FXD CER 0.02 UF 20% 100VDCW	56289	C023F101H203MS22CDH
A1C11	0160-3459		C:FXD CER 0.02 UF 20% 100VDCW	56289	C023F101H203MS22CDH
A1C12	0180-0374		C:FXD TANT. 10 UF 10% 20VDCW	56289	1500106X902082-DYS
A1C13	0160-2055		C:FXD CER 0.01 UF +80-20% 100VDCW	56289	C023F101F103ZS22-CDH
A1C14	0160-2055		C:FXD CER 0.01 UF +80-20% 100VDCW	56289	C023F101F103ZS22-CDH
A1CR1	1901-0040	2	DIODE:SILICON 30MA 30WV	07263	FDG1088
A1CR2			NOT ASSIGNED		
A1CR3	1901-0040		DIODE:SILICON 30MA 30WV	07263	FDG1088
A1Q1	1853-0020	13	TSTR:SI PNP(SELECTED FROM 2N3702)	28480	1853-0020
A1Q2	1853-0020		TSTR:SI PNP(SELECTED FROM 2N3702)	28480	1853-0020
A1Q3	1853-0020		TSTR:SI PNP(SELECTED FROM 2N3702)	28480	1853-0020
A1Q4	1854-0071	22	TSTR:SI NPN(SELECTED FROM 2N3704)	28480	1854-0071
A1Q5	1854-0071		TSTR:SI NPN(SELECTED FROM 2N3704)	28480	1854-0071
A1Q6	1853-0001	3	TSTR:SI PNP(SELECTED FROM 2N1132)	28480	1853-0001
A1Q7	1854-0221	2	TSTR:SI NPN(REPL.BY 2N4044)	28480	1854-0221
A1Q8	1854-0071		TSTR:SI NPN(SELECTED FROM 2N3704)	28480	1854-0071
A1Q9	1854-0071		TSTR:SI NPN(SELECTED FROM 2N3704)	28480	1854-0071
A1Q10	1854-0071		TSTR:SI NPN(SELECTED FROM 2N3704)	28480	1854-0071
A1Q11	1853-0001		TSTR:SI PNP(SELECTED FROM 2N1132)	28480	1853-0001
A1Q12	1854-0221		TSTR:SI NPN(REPL.BY 2N4044)	28480	1854-0221
A1Q13	1854-0071		TSTR:SI NPN(SELECTED FROM 2N3704)	28480	1854-0071
A1Q14	1853-0020		TSTR:SI PNP(SELECTED FROM 2N3702)	28480	1853-0020
A1Q15	1853-0020		TSTR:SI PNP(SELECTED FROM 2N3702)	28480	1853-0020
A1R1	0698-3260	9	R:FXD MET FLM 464K OHM 1% 1/8W	28480	0698-3260
A1R2	0686-1055	1	R:FXD COMP 1 MEGOHM 5% 1/2W	01121	EB 1055
A1R3	0698-3160	13	R:FXD MET FLM 31.6K OHM 1% 1/8W	28480	0698-3160
A1R5	0698-3160		R:FXD MET FLM 31.6K OHM 1% 1/8W	28480	0698-3160
A1R6	0698-3160		R:FXD MET FLM 31.6K OHM 1% 1/8W	28480	0698-3160
A1R6			NOT ASSIGNED		
A1R7	0698-3156	7	R:FXD MET FLM 14.7K OHM 1% 1/8W	28480	0698-3156
A1R8	0757-0465	9	R:FXD MET FLM 100K OHM 1% 1/8W	28480	0757-0465
A1R9	0698-3136	1	R:FXD MET FLM 17.8K OHM 1% 1/8W	28480	0698-3136
A1R10	0698-3441	3	R:FXD MET FLM 215 OHM 1% 1/8W	28480	0698-3441
A1R11	0757-0401	4	R:FXD MET FLM 100 OHM 1% 1/8W	28480	0757-0401
A1R12	2100-1770	2	R:VAR WW 100 OHM 5% TYPE H 1W	28480	2100-1770
A1R12	0757-0439	4	R:FXD MET FLM 6.81K OHM 1% 1/8W (FOR OPT 013)	28480	0757-0439
A1R12	0698-3449	2	R:FXD MET FLM 28.7K OHM 1% 1/8W (OPT 011)	28480	0698-3449
A1R13	0757-0461	4	R:FXD MET FLM 68.1K OHM 1% 1/8W	28480	0757-0461
A1R13	0757-0443	2	R:FXD MET FLM 11.0K OHM 1% 1/8W (FOR OPT 013)	28480	0757-0443
A1R13	0698-3162	2	R:FXD MET FLM 46.4K OHM 1% 1/8W (OPT 011)	28480	0698-3162
A1R14	0811-2284	5	R:FXD WW 1K OHM 0.1% 1/40W	28480	0811-2284
A1R15	0757-0199	7	R:FXD MET FLM 21.5K OHM 1% 1/8W	28480	0757-0199
A1R16	0811-2284		R:FXD WW 1K OHM 0.1% 1/40W	28480	0811-2284
A1R17			NOT ASSIGNED		
A1R18			NOT ASSIGNED		
A1R19	0698-3441		R:FXD MET FLM 215 OHM 1% 1/8W	28480	0698-3441
A1R20	0698-3160		R:FXD MET FLM 31.6K OHM 1% 1/8W	28480	0698-3160
A1R21	0698-3160		R:FXD MET FLM 31.6K OHM 1% 1/8W	28480	0698-3160
A1R22	0698-3156		R:FXD MET FLM 14.7K OHM 1% 1/8W	28480	0698-3156
A1R23	0757-0465		R:FXD MET FLM 100K OHM 1% 1/8W	28480	0757-0465
A1R24	0757-0401		R:FXD MET FLM 100 OHM 1% 1/8W	28480	0757-0401
A1R25	2100-1770		R:VAR WW 100 OHM 5% TYPE H 1W	28480	2100-1770
A1R26	0757-0461		R:FXD MET FLM 68.1K OHM 1% 1/8W	28480	0757-0461
A1R27	0811-2284		R:FXD WW 1K OHM 0.1% 1/40W	28480	0811-2284
A1R28	0757-0199		R:FXD MET FLM 21.5K OHM 1% 1/8W	28480	0757-0199
A1R29	0811-2284		R:FXD WW 1K OHM 0.1% 1/40W	28480	0811-2284
A1R30	0757-0199		R:FXD MET FLM 21.5K OHM 1% 1/8W	28480	0757-0199
A1R31	0698-3260		R:FXD MET FLM 464K OHM 1% 1/8W	28480	0698-3260
A1R32	0757-0289	2	R:FXD MET FLM 13.3K OHM 1% 1/8W (FOR OPT 012)	28480	0757-0289

See introduction to this section for ordering information.

Table 6-1. Replaceable Parts

Reference Designation	HP Part Number	Qty	Description	Mfr Code	Mfr Part Number
A1R32	0757-0439		R:FXD MET FLM 6.81K OHM 1% 1/8W (FOR OPT 013)	28480	0757-0439
A1R32	0698-3449		R:FXD MET FLM 28.7K OHM 1% 1/8W (OPT 011)	28480	0698-3449
A1R32	0757-0465		R:FXD MET FLM 100K OHM 1% 1/8W	28480	0757-0465
A1R33	0757-0465		R:FXD MET FLM 100K OHM 1% 1/8W	28480	0757-0465
A1R34	0757-0442	11	R:FXD MET FLM 10.0K OHM 1% 1/8W	28480	0757-0442
A1R35	0757-0279	7	R:FXD MET FLM 3.16K OHM 1% 1/8W	28480	0757-0279
A1R36	0757-0279		R:FXD MET FLM 3.16K OHM 1% 1/8W	28480	0757-0279
A1R37	0757-0279		R:FXD MET FLM 3.16K OHM 1% 1/8W	28480	0757-0279
A1R38	0757-0279		R:FXD MET FLM 3.16K OHM 1% 1/8W	28480	0757-0279
A1R39	0757-0279		R:FXD MET FLM 3.16K OHM 1% 1/8W	28480	0757-0279
A1R40	0698-3160		R:FXD MET FLM 31.6K OHM 1% 1/8W	28480	0698-3160
A1R41	0698-3160		R:FXD MET FLM 31.6K OHM 1% 1/8W	28480	0698-3160
A1R42	0757-0199		R:FXD MET FLM 21.5K OHM 1% 1/8W (FOR OPT 012)	28480	0757-0199
A1R42	0757-0443		R:FXD MET FLM 11.0K OHM 1% 1/8W (FOR OPT 013)	28480	0757-0443
A1R42	0698-3162		R:FXD MET FLM 46.4K OHM 1% 1/8W (OPT 011)	28480	0698-3162
A1R42	0698-3455	1	R:FXD MET FLM 261K OHM 1% 1/8W (OPT 010)	28480	0698-3455
A1R42	2100-1618	2	R:VAR FLM 1 MEGOHM 20% LIN 1/2W	28480	2100-1618
A1R44	0683-1855	1	R:FXD COMP 1.8 MEGOHM 5% 1/4W	01121	CB 1855
A1TP1	0360-0124	17	TERMINAL:SOLDER LUG	28480	0360-0124
A1TP2	0360-0124		TERMINAL:SOLDER LUG	28480	0360-0124
A1TP3			PART OF PC BOARD		
A1TP4	0360-0124		TERMINAL:SOLDER LUG	28480	0360-0124
A1TP5			PART OF PC BOARD		
A1TP6	0360-0124		TERMINAL:SOLDER LUG	28480	0360-0124
A1TP7	0360-0124		TERMINAL:SOLDER LUG	28480	0360-0124
A1TP8	0360-0124		TERMINAL:SOLDER LUG	28480	0360-0124
A1TP9	0360-0124		TERMINAL:SOLDER LUG	28480	0360-0124
A2	00432-6015		BOARD ASSY:LOGIC	28480	00432-6015
A2C1	0180-1819	1	C:FXD ELECT 100 UF +75-10% 50VDCW	28480	0180-1819
A2C2	0180-0229	3	C:FXD ELECT 33 UF 10% 10VDCW	28480	0180-0229
A2C3	0160-2917	6	C:FXD CER 0.05 UF +80-20% 100VDCW NOT ASSIGNED	84411	TYPE TA
A2C4			NOT ASSIGNED		
A2C5	0160-2917		C:FXD CER 0.05 UF +80-20% 100VDCW NOT ASSIGNED	84411	TYPE TA
A2C6			NOT ASSIGNED		
THRU					
A2C20			NOT ASSIGNED		
A2C21	0140-0234	2	C:FXD MICA 500 PF 1%	28480	0140-0234
A2C22	0140-0234		C:FXD MICA 500 PF 1%	28480	0140-0234
A2C23	0180-1746	1	C:FXD ELECT 15 UF 10% 20VDCW	28480	0180-1746
A2C24	0140-0210	1	C:FXD MICA 270 PF 5%	28480	0140-0210
A2C25	0160-0978	1	C:FXD MICA 1500 PF 1% 500VDCW	28480	0160-0978
A2C26	0160-2930	4	C:FXD CER 0.01 UF +80-20% 100VDCW NOT ASSIGNED	91418	TA
A2C27			NOT ASSIGNED		
A2C28			NOT ASSIGNED		
A2C29	0180-2178	1	C:FXD ELECT 220 UF 20% 8VDCW	56289	109D227X0008F2-DYP
A2C30	0160-2930		C:FXD CER 0.01 UF +80-20% 100VDCW	91418	TA
A2C31	0180-1940	1	C:FXD ELECT 33 UF 10% 15VDCW	56289	109D336X9015C2-DYP
A2C33	0180-0197	5	C:FXD ELECT 2.2 UF 10% 20VDCW	56289	150D225X9020A2-DYS
A2C34	0160-2672	1	C:FXD MY 0.047 UF 5% 80VDCW	28480	0160-2672
A2C35	0180-0197		C:FXD ELECT 2.2 UF 10% 20VDCW	56289	150D225X9020A2-DYS
A2C36	0160-2917		C:FXD CER 0.05 UF +80-20% 100VDCW NOT ASSIGNED	84411	TYPE TA
A2C37			NOT ASSIGNED		
A2C38	0160-2917		C:FXD CER 0.05 UF +80-20% 100VDCW	84411	TYPE TA
A2C39	0160-2150	1	C:FXD MICA 33 PF 5%	28480	0160-2150
A2C40	0180-0229		C:FXD ELECT 33 UF 10% 10VDCW	28480	0180-0229
A2C41	0160-2917		C:FXD CER 0.05 UF +80-20% 100VDCW	84411	TYPE TA
A2C42	0180-0106	2	C:FXD ELECT 60 UF 20% 6VDCW	28480	0180-0106
A2C43	0180-0197		C:FXD ELECT 2.2 UF 10% 20VDCW	56289	150D225X9020A2-DYS
A2C44	0180-0197		C:FXD ELECT 2.2 UF 10% 20VDCW	56289	150D225X9020A2-DYS
A2C45	0180-0106		C:FXD ELECT 60 UF 20% 6VDCW	28480	0180-0106
A2C45	0180-1714	1	C:FXD ELECT 330 UF 10% 6VDCW (OPT 011,012,013)	28480	0180-1714
A2C45			NOT ASSIGNED		
A2C46	0160-2253	1	C:FXD CER 6.8 PF 500VDCW	72982	301-NPD-6.8 PF
A2C47	0160-2930		C:FXD CER 0.01 UF +80-20% 100VDCW NOT ASSIGNED	91418	TA
A2C48			NOT ASSIGNED		
A2C49	0180-0229		C:FXD ELECT 33 UF 10% 10VDCW	28480	0180-0229
A2C50	0160-2917		C:FXD CER 0.05 UF +80-20% 100VDCW	84411	TYPE TA
A2CR1	1901-0026	20	DIODE:SILICON 0.75A 200PIV	04713	SR1358-8
A2CR2	1901-0026		DIODE:SILICON 0.75A 200PIV	04713	SR1358-8
A2CR3	1901-0026		DIODE:SILICON 0.75A 200PIV	04713	SR1358-8

See introduction to this section for ordering information

Table 6-1. Replaceable Parts

Reference Designation	HP Part Number	Qty	Description	Mfr Code	Mfr Part Number
A2CR4	1901-0026	1	DIODE:SILICON 0.75A 200PIV	04713	SR1358-8
A2CR5	1901-0026		DIODE:SILICON 0.75A 200PIV	04713	SR1358-8
A2CR6	1902-0509		DIODE BREAKDOWN+6.20V 2X	04713	SZ50984
A2CR7	1901-0026		DIODE:SILICON 0.75A 200PIV	04713	SR1358-8
A2CR8	1901-0026		DIODE:SILICON 0.75A 200PIV	04713	SR1358-8
A2CR9			NOT ASSIGNED		
A2CR10			NOT ASSIGNED		
A2CR11	1901-0026		DIODE:SILICON 0.75A 200PIV	04713	SR1358-8
A2CR12	1901-0026		DIODE:SILICON 0.75A 200PIV	04713	SR1358-8
A2CR13			NOT ASSIGNED		
A2CR14	1901-0026		DIODE:SILICON 0.75A 200PIV	04713	SR1358-8
A2CR15	1901-0026		DIODE:SILICON 0.75A 200PIV	04713	SR1358-8
A2CR16	1901-0026		DIODE:SILICON 0.75A 200PIV	04713	SR1358-8
A2CR17	1901-0026		DIODE:SILICON 0.75A 200PIV	04713	SR1358-8
A2CR18	1901-0026		DIODE:SILICON 0.75A 200PIV	04713	SR1358-8
A2CR19	1901-0026		DIODE:SILICON 0.75A 200PIV	04713	SR1358-8
A2CR20	1901-0026		DIODE:SILICON 0.75A 200PIV	04713	SR1358-8
A2CR21	1901-0026		DIODE:SILICON 0.75A 200PIV	04713	SR1358-8
A2CR22	1901-0026		DIODE:SILICON 0.75A 200PIV	04713	SR1358-8
A2CR23	1901-0026		DIODE:SILICON 0.75A 200PIV	04713	SR1358-8
A2Q1	1854-0071	1	TSTR:SI NPN(SELECTED FROM 2N3704)	28480	1854-0071
A2Q2	1854-0062		TSTR:SI NPN	80131	2N1701
A2Q3	1854-0071		TSTR:SI NPN(SELECTED FROM 2N3704)	28480	1854-0071
A2Q4	1853-0012		TSTR:SI PNP	80131	2N2904A
A2Q5	1853-0020		TSTR:SI PNP(SELECTED FROM 2N3702)	28480	1853-0020
A2Q6	1853-0020	1	TSTR:SI PNP(SELECTED FROM 2N3702)	28480	1853-0020
A2Q7	1853-0020		TSTR:SI PNP(SELECTED FROM 2N3702)	28480	1853-0020
A2Q8	1854-0071		TSTR:SI NPN(SELECTED FROM 2N3704)	28480	1854-0071
A2Q9	1854-0003		TSTR:SI NPN(SELECTED FROM 2N1711)	28480	1854-0003
A2Q10	1853-0001		TSTR:SI PNP(SELECTED FROM 2N1132)	28480	1853-0001
A2Q11	1854-0071	2	TSTR:SI NPN(SELECTED FROM 2N3704)	28480	1854-0071
A2Q12			NOT ASSIGNED		
A2Q19			NOT ASSIGNED		
A2Q20	1853-0020		TSTR:SI PNP(SELECTED FROM 2N3702)	28480	1853-0020
A2Q21	1854-0005		TSTR:SI NPN	80131	2N708
A2Q22	1854-0071	2	TSTR:SI NPN(SELECTED FROM 2N3704)	28480	1854-0071
A2Q23	1854-0071		TSTR:SI NPN(SELECTED FROM 2N3704)	28480	1854-0071
A2Q24	1854-0005		TSTR:SI NPN	80131	2N708
A2Q25			NOT ASSIGNED		
A2Q26	1854-0071		TSTR:SI NPN(SELECTED FROM 2N3704)	28480	1854-0071
A2Q27	1854-0071	2	TSTR:SI NPN(SELECTED FROM 2N3704)	28480	1854-0071
A2Q28	1854-0009		TSTR:SI NPN	80131	2N709
A2Q29	1854-0009		TSTR:SI NPN	80131	2N709
A2Q30	1855-0062		TSTR:SI FET 30V	01295	2N1595
A2Q31			NOT ASSIGNED		
A2Q32	1855-0062	1	TSTR:SI FET 30V	01295	2N1595
A2Q33			NOT ASSIGNED		
A2Q34	1854-0071		TSTR:SI NPN(SELECTED FROM 2N3704)	28480	1854-0071
A2Q35	1854-0071		TSTR:SI NPN(SELECTED FROM 2N3704)	28480	1854-0071
A2Q36	1853-0015		TSTR:SI PNP	80131	2N3640
A2Q37	1853-0020	1	TSTR:SI PNP(SELECTED FROM 2N3702)	28480	1853-0020
A2Q38	1855-0062		TSTR:SI FET 30V	01295	2N1595
A2Q39	1854-0071		TSTR:SI NPN(SELECTED FROM 2N3704)	28480	1854-0071
A2Q40	1854-0071		TSTR:SI NPN(SELECTED FROM 2N3704)	28480	1854-0071
A2Q41	1853-0020		TSTR:SI PNP(SELECTED FROM 2N3702)	28480	1853-0020
A2Q42	1853-0020	1	TSTR:SI PNP(SELECTED FROM 2N3702)	28480	1853-0020
A2Q43	1854-0071		TSTR:SI NPN(SELECTED FROM 2N3704)	28480	1854-0071
A2Q44	1854-0071		TSTR:SI NPN(SELECTED FROM 2N3704)	28480	1854-0071
A2R1	0757-0279		R:FXD MET FLM 3.16K OHM 1% 1/8W	28480	0757-0279
A2R2	0683-0685		R:FXD COMP 6.8 OHM 5% 1/4W	01121	C66865
A2R3	0757-0835	1	R:FXD MET FLM 6.81K OHM 1% 1/2W	28480	0757-0835
A2R4			NOT ASSIGNED		
A2R5	0757-0447		R:FXD MET FLM 16.2K OHM 1% 1/8W	28480	0757-0447
A2R6	2100-1773		R:VAR WW 1K OHM 5% TYPE H 1W	28480	2100-1773
A2R7	0757-0289		R:FXD MET FLM 13.3K OHM 1% 1/8W	28480	0757-0289
A2R8	0757-0280	4	R:FXD MET FLM 1K OHM 1% 1/8W	28480	0757-0280
A2R9	0757-0458		R:FXD MET FLM 51.1K OHM 1% 1/4W	28480	0757-0458
A2R10	0757-0401		R:FXD MET FLM 100 OHM 1% 1/8W	28480	0757-0401
A2R11	0757-0465		R:FXD MET FLM 100K OHM 1% 1/8W	28480	0757-0465
A2R12	0757-0442		R:FXD MET FLM 10.0K OHM 1% 1/3W	28480	0757-0442
A2R13	0757-0447	2	R:FXD MET FLM 16.2K OHM 1% 1/8W	28480	0757-0447
A2R14			NOT ASSIGNED		
A2R15	0757-0442		R:FXD MET FLM 10.0K OHM 1% 1/4W	28480	0757-0442
A2R16	0757-0279		R:FXD MET FLM 3.16K OHM 1% 1/4W	28480	0757-0279
A2R17	0757-0198		R:FXD MET FLM 100 OHM 1% 1/2W	28480	0757-0198

See introduction to this section for ordering information

Table 6-1. Replaceable Parts

Reference Designation	HP Part Number	Qty	Description	Mfr Code	Mfr Part Number
A2R18 A2R19 A2R20 A2R21 A2R22	0698-3401 0698-3156 0757-0442	1	R:FXD MET FLM 215 OHM 1% 1/2W NOT ASSIGNED NOT ASSIGNED R:FXD MET FLM 14.7K OHM 1% 1/8W R:FXD MET FLM 10.0K OHM 1% 1/8W	28480 28480 28480	7698-3401 0698-3156 0757-0442
A2R23 A2R24 A2R25 A2R26 A2R27	0757-0442 0698-3260 0698-3260 0757-0442 0757-0442		R:FXD MET FLM 10.0K OHM 1% 1/8W R:FXD MET FLM 464K OHM 1% 1/8W R:FXD MET FLM 464K OHM 1% 1/8W R:FXD MET FLM 10.0K OHM 1% 1/8W R:FXD MET FLM 10.0K OHM 1% 1/8W	28480 28480 28480 28480 28480	0757-0442 0698-3260 0698-3260 0757-0442 0757-0442
A2R28 A2R29 A2R30 A2R31 A2R32	0698-3156 0757-0397 0757-0199	1	R:FXD MET FLM 14.7K OHM 1% 1/8W R:FXD MET FLM 68.1 OHM 1% 1/8W NOT ASSIGNED NOT ASSIGNED R:FXD MET FLM 21.5K OHM 1% 1/8W	28480 28480 28480	0698-3156 0757-0397 0757-0199
A2R33 A2R34 A2R35 A2R36 A2R37	0757-0442 0757-0465 0698-3266 0757-0461 0698-3160	1	R:FXD MET FLM 10.0K OHM 1% 1/8W R:FXD MET FLM 100K OHM 1% 1/8W R:FXD MET FLM 237K OHM 1% 1/8W R:FXD MET FLM 68.1K OHM 1% 1/8W R:FXD MET FLM 31.6K OHM 1% 1/8W	28480 28480 28480 28480 28480	0757-0442 0757-0465 0698-3266 0757-0461 0698-3160
A2R38 A2R39 A2R40 A2R41 A2R42	0757-0465 0698-3155 0698-3155 0757-0465 0683-1065	4	R:FXD MET FLM 100K OHM 1% 1/8W R:FXD MET FLM 4.64K OHM 1% 1/8W R:FXD MET FLM 4.64K OHM 1% 1/8W R:FXD MET FLM 100K OHM 1% 1/8W	28480 28480 28480 28480	0757-0465 0698-3155 0698-3155 0757-0465
A2R43 A2R44 A2R45 A2R46 A2R47	0757-1094 0757-0465 0683-1065	3	R:FXD COMP 10M OHM 5% 1/4W	01121	CB 1065
A2R48 A2R49 A2R50 A2R51 A2R52	0757-1094 0757-0280 0698-3260 0757-0279	1	R:FXD MET FLM 1.47K OHM 1% 1/8W NOT ASSIGNED NOT ASSIGNED R:FXD MET FLM 100K OHM 1% 1/8W R:FXD COMP 10M OHM 5% 1/4W	28480 01121	0757-1094 0757-0280 0698-3260 CB 1065
A2R53 A2R54 A2R55 A2R56 A2R57	0757-0280 0698-3260 0757-0279		R:FXD MET FLM 1K OHM 1% 1/8W R:FXD MET FLM 464K OHM 1% 1/8W R:FXD MET FLM 3.16K OHM 1% 1/8W	28480 28480 28480	0757-0280 0698-3260 0757-0279
A2R58 A2R59 A2R60 A2R61	0698-3160 0698-3428 0698-3160 0698-3260	1	R:FXD MET FLM 31.6K OHM 1% 1/8W R:FXD MET FLM 14.7 OHM 1% 1/8W R:FXD MET FLM 31.6K OHM 1% 1/8W R:FXD MET FLM 464K OHM 1% 1/8W	28480 28480 28480 28480	0698-3160 0698-3428 0698-3160 0698-3260
A2R62 A2R63 A2R64 A2R65	0698-3260 0757-0439 0757-0442		FACTORY SELECTED PART		
A2R66 A2R67 A2R68 A2R69 A2R70	0757-0442 0698-3260 0698-3260 0698-0084 0683-1055	2	R:FXD MET FLM 10.0K OHM 1% 1/8W R:FXD MET FLM 464K OHM 1% 1/8W R:FXD MET FLM 464K OHM 1% 1/8W R:FXD MET FLM 2.15K OHM 1% 1/8W	28480 28480 28480 28480	0757-0442 0698-3260 0698-3260 0698-0084
A2R71 A2R72 A2R73 A2R74 A2R75	0683-1055	1	R:FXD COMP 1 MEGOHM 5% 1/4W	01121	CB 1055
A2R76 A2R77 A2R78 A2R79 A2R80	0757-0442 0698-3260 0698-3260 0698-0084 0683-1055		NOT ASSIGNED NOT ASSIGNED		
A2R81 A2R82 A2R83 A2R84 A2R85	0698-3260 0757-0439 0757-0442		R:FXD MET FLM 464K OHM 1% 1/8W R:FXD MET FLM 6.81K OHM 1% 1/8W R:FXD MET FLM 10.0K OHM 1% 1/8W	28480 28480 28480	0698-3260 0757-0439 0757-0442
A2R86 A2R87 A2R88 A2R89 A2R90	0757-0461 0698-3160 0757-0442 0698-3438 0698-3156	1	R:FXD MET FLM 68.1K OHM 1% 1/8W R:FXD MET FLM 31.6K OHM 1% 1/8W R:FXD MET FLM 10.0K OHM 1% 1/8W R:FXD MET FLM 147 OHM 1% 1/8W R:FXD MET FLM 14.7K OHM 1% 1/8W	28480 28480 28480 28480 28480	0757-0461 0698-3160 0757-0442 0698-3438 0698-3156
A2R91 A2R92 A2R93 A2R94 A2R95	0698-3160 0757-0401 0757-0199 2100-1769 0698-4466	1	R:FXD MET FLM 31.6K OHM 1% 1/8W R:FXD MET FLM 100 OHM 1% 1/8W R:FXD MET FLM 21.5K OHM 1% 1/8W	28480 28480 28480	0698-3160 0757-0401 0757-0199
A2R96 A2R97 A2R98 A2R99 A2R00	0757-0346 0698-3160 0811-2277 0811-2277 0811-2537	1	R:VAR WW 50 OHM 5% TYPE H 1W R:FXD MET FLM 976 OHM 1% 1/8W	28480 28480	2100-1769 0698-4466
A2R01 A2R02 A2R03 A2R04 A2R05	0757-0346 0698-3160 0811-2277 0811-2277 0811-2537	14	R:FXD MET FLM 10 OHM 1% 1/8W R:FXD MET FLM 31.6K OHM 1% 1/8W	28480 28480	0757-0346 0698-3160
A2R06 A2R07 A2R08 A2R09 A2R10	0811-2277 0811-2277 0811-2537	3	R:FXD WW 10K OHM 0.1% 1/40W R:FXD WW 10K OHM 0.1% 1/40W R:FXD WW 5K OHM 0.1% 1/40W	28480 28480 28480	0811-2277 0811-2277 0811-2537
A2R11 A2R12 A2R13 A2R14 A2R15	0698-3441	1	NOT ASSIGNED NOT ASSIGNED R:FXD MET FLM 215 OHM 1% 1/8W NOT ASSIGNED NOT ASSIGNED	28480	0698-3441
A2R16 A2R17 A2R18 A2S1 A2TPI	2100-1618 0683-1065 0757-0405 3101-0973 0360-0124	1	R:VAR FLM 1 MEGOHM 20% LIN 1/2W R:FXD COMP 10M OHM 5% 1/4W R:FXD MET FLM 162 OHM 1% 1/8W SWITCH:SLIDE OPDT 0.5A 125V AC/DC TERMINAL:SOLDER LUG	28480 01121 28480 79727 28480	2100-1618 CB 1065 0757-0405 G126-0018 0360-0124

See introduction to this section for ordering information

Table 6-1. Replaceable Parts

Reference Designation	HP Part Number	Qty	Description	Mfr Code	Mfr Part Number
A2TP2	0360-0124		TERMINAL:SOLDER LUG	28480	0360-0124
A2TP3	0360-0124		TERMINAL:SOLDER LUG	28480	0360-0124
A2TP4	0360-0124		TERMINAL:SOLDER LUG	28480	0360-0124
A2TP5	0360-0124		TERMINAL:SOLDER LUG	28480	0360-0124
A2TP6	0360-0124		TERMINAL:SOLDER LUG	28480	0360-0124
A2TP7	0360-0124		TERMINAL:SOLDER LUG	28480	0360-0124
A2TP8	0360-0124		TERMINAL:SOLDER LUG	28480	0360-0124
A2TP9	0360-0124		TERMINAL:SOLDER LUG	28480	0360-0124
A2TP10	0360-0124		TERMINAL:SOLDER LUG	28480	0360-0124
A3	00432-6003	1	SWITCH ASSY:RANGE	28480	00432-6003
A3R1	0811-2536	1	R:FXD WW 3167 OHM 0.1% 1/40W	28480	0811-2536
A3R2	0811-2284	1	R:FXD WW 1K OHM 0.1% 1/40W	28480	0811-2284
A3R3	0811-2534	1	R:FXD WW 314.3 OHM 0.1% 1/40W	28480	0811-2534
A3R4	0811-2535	1	R:FXD WW 145.0 OHM 0.1% 1/40W	28480	0811-2535
A3S1	3100-2470	1	SWITCH:ROTARY	28480	3100-2470
A4	00432-6004	1	SWITCH ASSY:CALIBRATION FACTOR	28480	00432-6004
A4R1	0757-0346		R:FXD MET FLM 10 OHM 1% 1/8W	28480	0757-0346
A4R2	0757-0346		R:FXD MET FLM 10 OHM 1% 1/8W	28480	0757-0346
A4R3	0757-0346		R:FXD MET FLM 10 OHM 1% 1/8W	28480	0757-0346
A4R4	0757-0346		R:FXD MET FLM 10 OHM 1% 1/8W	28480	0757-0346
A4R5	0757-0346		R:FXD MET FLM 10 OHM 1% 1/8W	28480	0757-0346
A4R6	0757-0346		R:FXD MET FLM 10 OHM 1% 1/8W	28480	0757-0346
A4R7	0757-0346		R:FXD MET FLM 10 OHM 1% 1/8W	28480	0757-0346
A4R8	0757-0346		R:FXD MET FLM 10 OHM 1% 1/8W	28480	0757-0346
A4R9	0757-0346		R:FXD MET FLM 10 OHM 1% 1/8W	28480	0757-0346
A4R10	0757-0346		R:FXD MET FLM 10 OHM 1% 1/8W	28480	0757-0346
A4R11	0757-0346		R:FXD MET FLM 10 OHM 1% 1/8W	28480	0757-0346
A4R12	0757-0346		R:FXD MET FLM 10 OHM 1% 1/8W	28480	0757-0346
A4R13	0698-6635	1	R:FXD MET FLM 880 OHM 1% 1/8W	28480	0698-6635
A4S1	3100-2469	1	SWITCH:ROTARY	28480	3100-2469
A5			NOT ASSIGNED		
A6			NOT ASSIGNED		
A7	00432-6007	1	BOARD ASSY:BATTERY CHARGER	28480	00432-6007
A7C1	0160-2930		(FOR OPTION 001) C:FXD CER 0.01 UF +80-20% 100VDCW	91418	TA
A7CR1	1901-0026		DIODE:SILICON 0.75A 200PLV	04713	SR1358-8
A7CR2	1902-0048	1	DIODE:BREAKDOWN 6.81V 5%	04713	SZ10939-134
A7Q1	1854-0039	1	TSTR:SI NPN	80131	2N3053
A7Q2	1853-0020		TSTR:SI NPN(SELECTED FROM 2N3702)	28480	1853-0020
A7Q3	1854-0071		TSTR:SI NPN(SELECTED FROM 2N3704)	28480	1854-0071
A7Q4	1854-0071		TSTR:SI NPN(SELECTED FROM 2N3704)	28480	1854-0071
A7R1	0698-3635	1	R:FXD MET 0X 680 OHM 5% 2W	28480	0698-3635
A7R2	0757-0280		R:FXD MET FLM 1K OHM 1% 1/8W	28480	0757-0280
A7R3	0757-0346		R:FXD MET FLM 10 OHM 1% 1/8W	28480	0757-0346
A7R4	0757-0439		R:FXD MET FLM 6.81K OHM 1% 1/8W	28480	0757-0439
A7R5	0757-0280		R:FXD MET FLM 1K OHM 1% 1/8W	28480	0757-0280
A7R6	0757-0199		R:FXD MET FLM 21.5K OHM 1% 1/8W	28480	0757-0199
A7R7	0698-3156		R:FXD MET FLM 14.7K OHM 1% 1/8W	28480	0698-3156
A7R8	2100-1776	1	FACTORY SELECTED PART R:VAR WW 10K OHM 5% TYPE H 1W	28480	2100-1776

See introduction to this section for ordering information



Table 6-1. Replaceable Parts

Reference Designation	HP Part Number	Qty	Description	Mfr Code	Mfr Part Number
			CHASSIS & MISCELLANEOUS PARTS		
B1	1420-0062	1	BATTERY:RECHARGEABLE 24V (OPT 001)	28480	1420-0062
C1	0160-3043	1	C:FXD CER 2 X 0.005 UF 20% 250VAC	56289	29C147A-CDH
C2	0180-0197		C:FXD ELECT 2.2 UF 10% 20VDCW (OPT 011, 012, 013)	56269	150D225X9020A2-OYS
C2			(OPT 011, 012, 013)		
DS1	2140-0244	1	LAMP:GLOW MINIATURE 95V	87034	A1H
F1	2110-0234	1	FUSE:0.1 AMP 250V SLOW-BLOW	75915	313-100/S
J1	1251-1280	1	CONNECTOR:AUDIO 6 FEMALE CONTACTS	28480	1251-1280
J1	00432-2005	1	NUT:CONNECTOR	28480	00432-2005
J2	1250-0118	3	CONNECTOR:BNC	24931	28JR 128-1
J3	1250-0118		CONNECTOR:BNC	24931	28JR 128-1
J4	1250-0118		CONNECTOR:BNC	24931	28JR 128-1
J5	1251-2357	1	SOCKET:3-PIN MALE POWER RECEPTACLE (PART OF REAR PANEL)	82389	EAC-301
J5					
M1	1120-1497	1	METER	28480	1120-1497
MP1	0370-0077	1	KNOB:SKIRTED BAR FOR 0.250" DIA SHAFT (RANGE)	28480	0370-0077
MP2	0370-0193	1	KNOB:ROTARY POINTER BLACK (CAL FACTOR)	28480	0370-0193
MP2					
MP3	0370-0432	1	KNOB:BLACK LEVER (MT. RES.)	28480	0370-0432
MP3					
MP4	5040-0345	6	INSULATOR:CONNECTOR(LIGHT GRAY)	28480	5040-0345
MP4	5040-0702	6	INSULATOR:CONNECTOR(BLACK)	28480	5040-0702
MP5	0403-0131	2	GUIDE:P.C. BOARD, GREY	28480	0403-0131
MP6	0403-0026	1	GLIDE:NYLON (OPT 001)	28480	0403-0026
MP6					
MP6	00432-0005	1	BRACKET:TRANSFORMER	28480	00432-0005
MP7	00432-0006	1	DECK:LOWER	28480	00432-0006
MP8	00432-0007	1	DECK:UPPER	28480	00432-0007
MP9	00432-0011	1	BRACKET:FRAME	28480	00432-0011
R1	2100-2849	1	R:VAR WW 50K OHM 3% LIN 2W	28480	2100-2849
R1	2950-0034	1	NUT:HEX BRASS 3/8-32 X 1/2"	28480	2950-0034
R1	00432-2004	1	BUSHING:PANEL	28480	00432-2004
R2	0811-2538	4	R:FXD WW 100 OHM 0.1% 1/10W	28480	0811-2538
R3	0811-2538		R:FXD WW 100 OHM 0.1% 1/10W	28480	0811-2538
R4	0811-2538		R:FXD WW 100 OHM 0.1% 1/10W	28480	0811-2538
R5	0811-2538		R:FXD WW 100 OHM 0.1% 1/10W	28480	0811-2538
R6	0757-0984	2	R:FXD MET FLM 10.0 OHM 1% 1/2W	28480	0757-0984
R7	0757-0984		R:FXD MET FLM 10.0 OHM 1% 1/2W	28480	0757-0984
R8	0757-0198		R:FXD MET FLM 100 OHM 1% 1/2W	28480	0757-0198
R9	0757-0458		R:FXD MET FLM 51.1K OHM 1% 1/8W	28480	0757-0458
R10	0757-0200	1	R:FXD MET FLM 5.62K OHM 1% 1/8W (FOR OPT 011)	28480	0757-0200
R10					
R10	0698-3151	1	R:FXD MET FLM 2.87K OHM 1% 1/8W	28480	0698-3151
R10			(OPT 012)		
R10	0757-0317	1	R:FXD MET FLM 1.33K OHM 1% 1/8W (FOR OPT 011)	28480	0757-0317
R10					
R11	0757-0288	1	R:FXD MET FLM 9.09K OHM 1% 1/8W (FOR OPT 011)	28480	0757-0288
R11					
R11	0698-3155		R:FXD MET FLM 4.64K OHM 1% 1/8W (OPT 012)	28480	0698-3155
R11	0698-0084		R:FXD MET FLM 2.15K OHM 1% 1/8W (OPT 013)	28480	0698-0084
R11					
R12	0698-3156		R:FXD MET FLM 14.7K OHM 1% 1/8W (OPT 012)	28480	0698-3156
R12					
R13	0698-3158	1	R:FXD MET FLM 23.7K OHM 1% 1/8W (OPT 012)	28480	0698-3158
R13					
R14	0811-2277		R:FXD WW 10K OHM 0.1% 1/40W	28480	0811-2277
S1	3101-1395	1	SWITCH:PUSHBUTTON DPDT-DB (POWER)	76854	53-67280-121/A1H
S1					
S2	3101-1234	1	SWITCH:SLIDE DPDT (PART OF REAR PANEL)	82389	11A-1242
S2					
S3	3100-2485	1	SWITCH:LEVER SINGLE SECTION (MT. RES.)	76854	TYPE 184
S3					
S3	00432-00031	1	SWITCH PLATE	28480	00432-00031
S4	3101-1357	1	SWITCH:TUGGLE SPDT (FINE ZERO)	09353	7109
S4					
S4	00432-2003	1	NUT:DRESS	28480	00432-2003
W1	8120-1082	1	CABLE ASSY:5 FT	28480	8120-1082
W1	8120-1083	1	CABLE ASSY:SPECIAL PURPOSE(10 FT) (OPT 009)	28480	8120-1083
W1					
W1	8120-1084	1	CABLE ASSY:SPECIAL PURPOSE(20 FT) (OPT 010)	28480	8120-1084
W1					

See introduction to this section for ordering information

Table 6-1. Replaceable Parts

Reference Designation	HP Part Number	Qty	Description	Mfr Code	Mfr Part Number
w1	8120-1359	1	THERMO CABLE:SPECIAL PURPOSE(50 FT) (OPT 011)	28480	8120-1359
w1	8120-1360	1	THERMO CABLE:SPECIAL PURPOSE(100 FT) (OPT 012)	28480	8120-1360
w1	8120-1361	1	THERMO CABLE:SPECIAL PURPOSE(200 FT) (OPT 013)	28480	8120-1361
w2	8120-1348	1	CABLE ASSY:POWER, DETACHABLE	70903	KHS-7041
w3	00432-6010	1	CABLE ASSY:POWER SWITCH	28480	00432-6010
XA1	1251-0172	2	CONNECTOR:PC EDGE 1 ROW 22 CONTACT (PART OF LOWER DECK)	71785	250-22-30-210
XA2	1251-0172		CONNECTOR:PC EDGE 1 ROW 22 CONTACT (PART OF LOWER DECK)	71785	250-22-30-210
XB1	00432-0008	1	BRACKET:BATTERY UPPER (OPT 001)	28480	00432-0008
XB1	00432-0009	1	BRACKET:BATTERY LOWER (OPT 001)	28480	00432-0009
XF1	1400-0084	1	FUSEHOLDER:EXTRACTOR POST TYPE	75915	342014

See introduction to this section for ordering information

Table 6-1. Replaceable Parts

Reference Designation	HP Part Number	Qty	Description	Mfr Code	Mfr Part Number
1	5060-0703		CABINET PARTS	28480	5060-0703
2	1490-0031		FRAME ASSY:6 X 11 SM	28480	1490-0031
3	5040-0700		STAND:TILT	28480	5040-0700
4	5060-0727		HINGE	28480	5060-0727
			FOOT ASSY	28480	5060-0727
5	5020-0700		SPACER:CABINET	28480	5020-0700
6	5000-0703		SIDE COVER-BLUE GRAY	28480	5000-0703
6	5000-8565		SIDE COVER-OLIVE GRAY	28480	5000-8565
7	5060-0706		TOP COVER-BLUE GRAY	28480	5060-0706
7	5060-8549		TOP COVER-OLIVE GRAY	50436	5060-8549
8	5000-0711		BOTTOM COVER-BLUE GRAY	28480	5000-0711
8	5000-8571		BOTTOM COVER-OLIVE GRAY	28480	5000-8571
9	00432-00022		REAR PANEL	50436	00432-00022
10	00432-00021		FRONT PANEL-LIGHT GRAY	50436	00432-00021
10	00432-00033		FRONT PANEL - MINT GRAY	50436	00432-00033
11	5020-0704		METER TRIM: - LIGHT GRAY	28480	5020-0704
11	5020-7633		METER TRIM: - MINT GRAY	28480	5020-7633

Table 6-2. Code List of Manufacturers











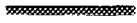

MFR NO.	MANUFACTURER NAME	ADDRESS	ZIP CODE
432H	MANUFACTURERS CODE LIST		PAGE 3
		AS OF 06/03/72	
01121	ALLEN BRADLEY CO.	MILWAUKEE, WIS.	53204
01295	TEXAS INSTRUMENTS INC. SEMICONDUCTOR COMPONENTS DIV.	DALLAS, TEX.	75231
04713	MOTOROLA SEMICONDUCTOR PROD. INC.	PHOENIX, ARIZ.	85008
07263	FAIRCHILD CAMERA & INST. CORP. SEMICONDUCTOR DIV.	MOUNTAIN VIEW, CALIF.	94040
09353	C & K COMPONENTS INC.	NEWTON, MASS.	02158
24931	SPECIALTY CONNECTOR CO. INC.	INDIANAPOLIS, IND.	46227
28480	HEWLETT-PACKARD CO. CORPORATE HQ	PALO ALTO, CALIF.	94304
50436	HEWLETT-PACKARD CO. MICROWAVE DIV	PALO ALTO, CALIF	94304
56289	SPRAGUE ELECTRIC CO.	N. ADAMS, MASS.	01247
70903	BELODEN CORP.	CHICAGO, ILL.	60644
71765	CINCH MFG. CO. DIV TRW INC.	ELK GROVE VILLAGE, ILL.	
72982	ERIE TECHNOLOGICAL PROD. INC.	ERIE, PA.	16512
75915	LITTELFUSE INC.	DES PLAINES, ILL.	60016
76854	JAK MFG. CO. DIV. JAK ELECTRODYNAMICS CORP.	CRYSTAL LAKE, ILL.	60014
79727	CONTINENTAL-AIPT ELECTRONICS CORP.	HARMINSTER, PA.	18974
80131	ELECTRONIC INDUSTRIES ASSOCIATION	WASHINGTON D.C.	20006
82389	SWITCHCRAFT INC.	CHICAGO, ILL.	60630
84411	TRW CAPACITOR DIV.	OGALLALA, WYBR.	69153
87034	MARONAK INDUSTRIES	ANAHEIM, CALIF.	92803
91418	RADIO MATERIALS CO.	CHICAGO, ILL.	60646

See introduction to this section for ordering information



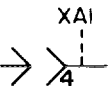

Table 7-1. Schematic Notes

1.		Resistance in ohms, capacitance in microfarads unless otherwise indicated.
2.		Screwdriver adjustment
		Front panel control
3.		Front panel designation
		Rear panel designation
4.		Printed circuit card border
		Main signal path
		Secondary signal path
		Secondary feedback path
5.		P/O = part of
6.		Wiper moves toward CW when control rotated clockwise
7.		Test point. Number in circle matches number on printed circuit card.
8.		Breakdown diode
9.		Tunnel diode
10.		Wire color code. Numerical color code same as resistor coding. For example, 947 denotes white, yellow, violet wire.
11.		Indicates socket connections and pin numbers.

## APPENDIX I MANUAL CHANGES

(BACKDATING)

### AI-1. INTRODUCTION

AI-2. This appendix contains information for adapting this manual to instruments for which the content does not directly apply.

AI-3. To adapt this manual to your instrument, refer to Table AI-1 and make all the changes listed opposite your instrument serial number. Perform these changes in the sequence listed.

AI-4. If your instrument serial number is not listed on the title page of this manual (or in Table 7-1), it may be documented in a MANUAL CHANGES supplement. For additional information about serial number coverage, refer to INSTRUMENT IDENTIFICATION in Section I.

### AI-5. CHANGE INSTRUCTIONS

#### CHANGE A

Table 6-1 and Service Sheet 2:  
Change A2C24 to 0140-0198 C:FXD 200 PF.  
Delete A2C48.  
Change A2R61-63 to 0698-3260 R:FXD MET FLM  
464K OHM 1% 1/8W.

#### CHANGE B

Table 6-1 and Service Sheet 2:  
Delete A2C49 (Junction of R57 and R59 connects directly to XA2-15).  
Delete A2R29 (C31 connects directly to ground).

#### CHANGE C

Table 6-1:  
Replace portion dealing with A2 Meter Logic Assy with Table A1-3.

Service Sheet 2:  
Replace with Figure A1-1.

Figures 7-11 and 7-13:  
Replace with Figures A1-2 and A1-3.

Table 6-1 and Service Sheet 1:  
Change A1C13,14 to 0160-2264 C:FXD 20 PF  
500 VDCW.

#### CHANGE D

Figure 4-4:  
Delete reference to A2S1.

Paragraphs 5-16, 5-18 and 5-37:  
Delete references to A2S1.

Table 6-1 and Service Sheet 2:  
Delete A2R88 and A2S1.

#### CHANGE E

Table 6-1 and Service Sheet 3:  
Change A7A7 to 0757-0199 R:FXD MET FLM  
21.5K OHM 1% 1/8W.  
Change A7R8 to 2100-1775 R:VAR WW 5K OHM  
5% TYPE H 1W.

#### CHANGE F

Table 6-1 and Service Sheets 2 and 3  
Change A2C46 to 0150-0059 C:FXD CER 3.3  
±0.25 PF 500 VCDW.  
Change A2R5,13 to 0698-3156 R:FXD MET FLM  
14.7 OHM 1% 1/8W.  
Change A2R35 to 0698-3454 R:FXD MET FLM  
215K OHM 1% 1/8W.

#### CHANGE G

Table 6-1 and Service Sheet 3:  
Change F1 to 2100-0027 FUSE 125 MA 250V.  
Change W2 to 8120-0078 CABLE ASSY: POWER  
CORD.  
Change S2 to 3101-0033 SWITCH: SLIDE DPDT  
0.5A 125V AC/DC.  
Change J5 to 1261-0148 CONNECTOR: POWER  
3 PIN MALE.

#### NOTE

To order a replacement rear panel, order the following parts (use current part numbers for S2 and J5):  
00432-00022 PANEL: REAR  
F1 2110-0234 FUSE 100 MA SLOW BLO  
250V  
W2 8120-1348 CABLE ASSY: POWER CORD

Figure 7-8:  
Replace with Figure A1-4.

#### CHANGE H

Table 6-1 and Service Sheet 1:  
Change A1C10,11 to 0160-2930 C:FXD CER .01  
UF +80-20% 100 VWDC.

Table AI-1. Manual Changes

Serial Prefix or Number	Make Manual Changes
812-00200 and below	L,K,J,I,H,G,F,E,D,C,B,A
812-00201 to 00225, 840-843-	L,K,J,I,H,G,F,E,D,C,B
904-, 919-,	L,K,J,I,H,G,F,E,D,C
937-01751 to 01850	L,K,J,I,H,G,F,E,D
937-01851 to 02950	L,K,J,I,H,G,F,E
937-02951 to 03050	L,K,J,I,H,G,F
968-03051 to 03550	L,K,J,I,H,G
968-03551 to 03650	L,K,J,I,H
992-	L,K,J,I
1102A04551 to 04650	L,K,J
1102A04651 to 06050	L,K
	L

Table AI-2. Summary of Changes by Component

Change	A1	A2	A3	A4	A5	A6	A7	Chassis
A		C21, 48 <sup>3</sup> R61-63						
B		C49 <sup>3</sup> R29						
C	C13,14 <sup>1</sup>							A2 <sup>4</sup>
D		R88 <sup>1</sup> S1						
E							R7,8 <sup>3</sup>	
F		C46 <sup>1</sup> R5,13,35						
G								F1,J5 <sup>1</sup> S2,W2 Rear Panel
H	C10,11 <sup>2</sup> R11, 24							
I								DS1, <sup>1</sup> R9 S1,3 Front Panel
J								A1 <sup>2</sup>
K		C44 <sup>1</sup> R72						
L								R6,7 <sup>2</sup>
<sup>1</sup> Original part is preferred replacement. <sup>2</sup> New part is preferred replacement.			<sup>3</sup> Modification to new part is recommended. <sup>4</sup> Modification to new part is recommended (must also use Modification Kit 00432-6023).					



Change A1R11, 24 to 0757-0416 R:FXD MET  
FLM 511 OHM 1% 1/8W.

## CHANGE I

Table 6-1 and Service Sheet 3:

Change DS1 to 2140-0015 LAMP: GLOW NEON  
NE2H.

Change R9 to 0698-3160 R:FXD MET FLM 31.6K  
OHM 1% 1/8W.

Change S1 to 3010-0957 SWITCH: TOGGLE  
DPDT.

Change S3 to 3101-1180 SWITCH: SLIDE 3 PDT.

Add: XDS1 5040-0235 BASE: LAMPHOLDER.

XDS1 5040-257 LAMPHOLDER  
00432-0003 PLATE: SWITCH  
0590-0041 NUT: KNURLED

## NOTE

To order a replacement front panel, order the  
following parts:

00432-0021 PANEL: FRONT(LIGHT GRAY)  
S1 3101-1394 SWITCH: PUSHBUTTON

R9 0757-0458 R:FXD MET FLM 51.1K  
OHM 1% 1/8W

DS1 2140-0244 LAMP: GLOW 95V  
S3 3100-2485 SWITCH: LEVER 4 PDT  
00432-00031 PLATE: SWITCH  
0370-0432 KNOB: LEVER

Figure 7-6:

Replace with Figure A1-5.

## CHANGE J

Figure 4-3:

Delete reference to A1R43,44.

Table 6-1 and Service Sheet 1:

Change A1 to 00432-6001 BOARD ASSY: BRIDGE

Delete A1R43,44.

## CHANGE K

Table 6-1 and Service Sheet 2:

Change A2C44 to 0180-0291 C:FXD ELECT 1.0  
UF 10% 35 VDCW.

Change A2R72 to 0698-3444 R:FXD 316 OHM 1%  
1/2W.

## CHANGE L

Table 6-1 and Service Sheet 3:

Change R6 and R7 to 0757-0198 R:FXD MET FLM  
100 OHM 1% 1/8W.

Table AI-3. Back-dating for Table 6-1 (Change C)

Reference Designation	HP Part Number	Qty	Description	Mfr Code	Mfr Part Number
A2	00432-6002	2	BOARD ASSY:LOGIC	28480	00432-6002
A2C1	0180-1819	1	C:FXD ELECT 100 UF +75-10% 50VDCW	28480	0180-1819
A2C2	0180-0229	2	C:FXD ELECT 33 UF 10% 10VDCW	28480	0180-0229
A2C3	0160-2917	6	C:FXD CER 0.05 UF +80-20% 100VDCW	84411	TYPE TA
A2C4	0160-2917		C:FXD CER 0.05 UF +80-20% 100VDCW	84411	TYPE TA
A2C4			FACTORY SELECTED PART		
A2C5	0160-2917		C:FXD CER 0.05 UF +80-20% 100VDCW	84411	TYPE TA
A2C6			NOT ASSIGNED		
A2C20			NOT ASSIGNED		
A2C21	0140-0234	2	C:FXD MICA 500 PF 1%	28480	0140-0234
A2C22	0140-0234		C:FXD MICA 500 PF 1%	28480	0140-0234
A2C23	0180-1746	1	C:FXD ELECT 15 UF 10% 20VDCW	28480	0180-1746
A2C24	0140-0198	1	C:FXD MICA 200 PF 5%	72136	RDM15F201J3C
A2C25	0160-0978	1	C:FXD MICA 1500 PF 1% 500VDCW	28480	0160-0978
A2C26	0160-2930	5	C:FXD CER 0.01 UF +80-20% 100VDCW	91418	TA
A2C27			NOT ASSIGNED		
A2C28	0160-2930		C:FXD CER 0.01 UF +80-20% 100VDCW	91418	TA
A2C29	0180-2173	1	C:FXD ELECT 220 UF 20% 8VDCW	56289	109D227X0008F2-DYP
A2C30	0160-2930		C:FXD CER 0.01 UF +80-20% 100VDCW	91418	TA
A2C31	0180-1940	1	C:FXD ELECT 33 UF 10% 15VDCW	56289	109D336X9015C2-DYP
A2C32	0160-2930		C:FXD CER 0.01 UF +80-20% 100VDCW	91418	TA
A2C33	0180-0197	4	C:FXD ELECT 2.2 UF 10% 20VDCW	56289	1500225X9020A2-DYS
A2C34	0160-2672	1	C:FXD MY 0.047 UF 5% 80VDCW	28480	0160-2672
A2C35	0180-0197		C:FXD ELECT 2.2 UF 10% 20VDCW	56289	1500225X9020A2-DYS
A2C36	0160-2917		C:FXD CER 0.05 UF +80-20% 100VDCW	84411	TYPE TA
A2C37	0160-2143	1	C:FXD CER 2000 PF +80-20% 100VDCW	91418	TYPE B
A2C38	0160-2917		C:FXD CER 0.05 UF +80-20% 100VDCW	84411	TYPE TA
A2C39	0160-2205	1	C:FXD CER 22 PF 5% 500VDCW	72982	301-NPU-22PF
A2C40	0180-0229		C:FXD ELECT 33 UF 10% 10VDCW	28480	0180-0229
A2C41	0160-2917		C:FXD CER 0.05 UF +80-20% 100VDCW	84411	TYPE TA
A2C42	0180-0106	2	C:FXD ELECT 6J UF 20% 6VDCW	28480	0180-0106
A2C43	0180-0197		C:FXD ELECT 2.2 UF 10% 20VDCW	56289	1500225X9020A2-DYS
A2C44	0180-0291	1	C:FXD ELECT 1.0 UF 10% 35VDCW	56289	1500105X9035A2-DYS
A2C45	0180-0106		C:FXD ELECT 6J UF 20% 6VDCW	28480	0180-0106
A2C46	0150-0059	1	C:FXD CER 3.3-0.25 PF 500VDCW	72982	301-000-C0JU-339C
A2C47	0160-2930		C:FXD CER 0.01 UF +80-20% 100VDCW	91418	TA
A2C48			NOT ASSIGNED		
A2C49	0180-0197		C:FXD ELECT 2.2 UF 10% 20VDCW	56289	1500225X9020A2-DYS
A2CR1	1901-0026	5	DIODE:SILICON 0.75A 200PIV	04713	SR1358-8
A2CR2	1901-0026		DIODE:SILICON 0.75A 200PIV	04713	SR1358-8
A2CR3	1901-0026		DIODE:SILICON 0.75A 200PIV	04713	SR1358-8
A2CR4	1901-0026		DIODE:SILICON 0.75A 200PIV	04713	SR1358-8
A2CR5			NOT ASSIGNED		
A2CR6	1902-0033	1	DIODE:BREAKDOWN 6.2V	04713	1N823
A2CR7	1901-0040	9	DIODE:SILICON 30MA 30WV	07263	FDG1088
A2CR8	1901-0026		DIODE:SILICON 0.75A 200PIV	04713	SR1358-8
A2CR9			NOT ASSIGNED		
A2CR10			NOT ASSIGNED		
A2CR11	1901-0040		DIODE:SILICON 30MA 30WV	07263	FDG1088
A2CR12	1901-0040		DIODE:SILICON 30MA 30WV	07263	FDG1088
A2CR13	1901-0040		DIODE:SILICON 30MA 30WV	07263	FDG1088
A2CR14	1901-0040		DIODE:SILICON 30MA 30WV	07263	FDG1088
A2CR15	1901-0040		DIODE:SILICON 30MA 30WV	07263	FDG1088
A2CR16	1901-0040		DIODE:SILICON 30MA 30WV	07263	FDG1088
A2CR17	1901-0040		DIODE:SILICON 30MA 30WV	07263	FDG1088
A2CR18	1901-0040		DIODE:SILICON 30MA 30WV	07263	FDG1088
A2Q1	1854-0071	18	TSTR:SI NPN(SELECTED FROM 2N3704)	28480	1854-0071
A2Q2	1854-0062	1	TSTR:SI NPN	80131	2N1701
A2Q3	1854-0071		TSTR:SI NPN(SELECTED FROM 2N3704)	28480	1854-0071
A2Q4	1853-0012	1	TSTR:SI PNP	80131	2N2904A
A2Q5	1853-0020	9	TSTR:SI PNP(SELECTED FROM 2N3702)	28480	1853-0020
A2Q6	1853-0020		TSTR:SI PNP(SELECTED FROM 2N3702)	28480	1853-0020
A2Q7	1853-0020		TSTR:SI PNP(SELECTED FROM 2N3702)	28480	1853-0020
A2Q8	1854-0071		TSTR:SI NPN(SELECTED FROM 2N3704)	28480	1854-0071
A2Q9	1854-0003	1	TSTR:SI NPN(SELECTED FROM 2N1711)	28480	1854-0003
A2Q10	1853-0001	1	TSTR:SI PNP(SELECTED FROM 2N1132)	28480	1853-0001
A2Q11	1854-0071		TSTR:SI NPN(SELECTED FROM 2N3704)	28480	1854-0071
A2Q12			NOT ASSIGNED		
A2Q19			NOT ASSIGNED		
A2Q20	1853-0020		TSTR:SI PNP(SELECTED FROM 2N3702)	28480	1853-0020
A2Q21	1854-0005	3	TSTR:SI NPN	80131	2N709
A2Q22	1854-0071		TSTR:SI NPN(SELECTED FROM 2N3704)	28480	1854-0071
A2Q23	1854-0071		TSTR:SI NPN(SELECTED FROM 2N3704)	28480	1854-0071
A2Q24	1854-0005		TSTR:SI NPN	80131	24708
A2Q25			NOT ASSIGNED		

See introduction to this section for ordering information

Table AI-3. Back-dating for Table 6-1 (Change C)

Reference Designation	HP Part Number	Qty	Description	Mfr Code	Mfr Part Number
A2026	1854-0071		TSTR:SI NPN(SELECTED FROM 2N3704)	28480	1854-0071
A2027	1854-0005		TSTR:SI NPN	80131	2N708
A2028	1854-0071		TSTR:SI NPN(SELECTED FROM 2N3704)	28480	1854-0071
A2029	1854-0071		TSTR:SI NPN(SELECTED FROM 2N3704)	28480	1854-0071
A2030	1854-0071		TSTR:SI NPN(SELECTED FROM 2N3704)	28480	1854-0071
A2031	1853-0020		TSTR:SI PNP(SELECTED FROM 2N3702)	28480	1853-0020
A2032	1854-0071		TSTR:SI NPN(SELECTED FROM 2N3704)	28480	1854-0071
A2033	1853-0020		TSTR:SI PNP(SELECTED FROM 2N3702)	28480	1853-0020
A2034	1854-0071		TSTR:SI NPN(SELECTED FROM 2N3704)	28480	1854-0071
A2035	1854-0071		TSTR:SI NPN(SELECTED FROM 2N3704)	28480	1854-0071
A2036	1853-0015	1	TSTR:SI PNP	80131	2N3640
A2037	1853-0020		TSTR:SI PNP(SELECTED FROM 2N3702)	28480	1853-0020
A2038	1854-0071		TSTR:SI NPN(SELECTED FROM 2N3704)	28480	1854-0071
A2039	1854-0071		TSTR:SI NPN(SELECTED FROM 2N3704)	28480	1854-0071
A2040	1854-0071		TSTR:SI NPN(SELECTED FROM 2N3704)	28480	1854-0071
A2041	1853-0020		TSTR:SI PNP(SELECTED FROM 2N3702)	28480	1853-0020
A2042	1853-0020		TSTR:SI PNP(SELECTED FROM 2N3702)	28480	1853-0020
A2043	1854-0071		TSTR:SI NPN(SELECTED FROM 2N3704)	28480	1854-0071
A2044	1854-0071		TSTR:SI NPN(SELECTED FROM 2N3704)	28480	1854-0071
A2R1	0757-0279	3	R:FXD MET FLM 3.16K OHM 1% 1/8W	28480	0757-0279
A2R2	0683-0685	1	R:FXD COMP 6.8 OHM 5% 1/4W	01121	CB68G5
A2R3	0757-0835	1	R:FXD MET FLM 6.81K OHM 1% 1/2W NOT ASSIGNED	28480	0757-0835
A2R4			NOT ASSIGNED		
A2K5	0698-3156	4	R:FXD MET FLM 14.7K OHM 1% 1/8W	28480	0698-3156
A2K7	0757-0289	1	R:FXD MET FLM 13.3K OHM 1% 1/8W	28480	0757-0289
A2R8	0757-0280	3	R:FXD MET FLM 1K OHM 1% 1/8W	28480	0757-0280
A2R9	0698-3160	6	R:FXD MET FLM 31.6K OHM 1% 1/8W	28480	0698-3160
A2R10	0698-3441	2	R:FXD MET FLM 215 OHM 1% 1/8W FACTORY SELECTED PART	28480	0698-3441
A2R10			FACTORY SELECTED PART		
A2R11	0757-0465	7	R:FXD MET FLM 100K OHM 1% 1/8W	28480	0757-0465
A2R12	0757-0442	11	R:FXD MET FLM 10.0K OHM 1% 1/8W	28480	0757-0442
A2K13	0698-3136	1	R:FXD MET FLM 17.8K OHM 1% 1/8W	28480	0698-3136
A2R14	0757-0346	2	R:FXD MET FLM 10 OHM 1% 1/8W FACTORY SELECTED PART	28480	0757-0346
A2R14			FACTORY SELECTED PART		
A2R15	0757-0442		R:FXD MET FLM 10.0K OHM 1% 1/8W	28480	0757-0442
A2R16	0757-0279		R:FXD MET FLM 3.16K OHM 1% 1/8W	28480	0757-0279
A2R17	0757-0198	1	R:FXD MET FLM 100 OHM 1% 1/2W NOT ASSIGNED	28480	0757-0198
A2R19			NOT ASSIGNED		
A2R20			NOT ASSIGNED		
A2K21	0698-3156		R:FXD MET FLM 14.7K OHM 1% 1/8W	28480	0698-3156
A2R22	0757-0442		R:FXD MET FLM 10.0K OHM 1% 1/8W	28480	0757-0442
A2R23	0757-0442		R:FXD MET FLM 10.0K OHM 1% 1/8W	28480	0757-0442
A2R24	0698-3260	9	R:FXD MET FLM 464K OHM 1% 1/8W	28480	0698-3260
A2R25	0698-3260		R:FXD MET FLM 464K OHM 1% 1/8W	28480	0698-3260
A2R26	0757-0442		R:FXD MET FLM 10.0K OHM 1% 1/8W	28480	0757-0442
A2K27	0757-0442		R:FXD MET FLM 10.0K OHM 1% 1/8W	28480	0757-0442
A2K28	0698-3156		R:FXD MET FLM 14.7K OHM 1% 1/8W	28480	0698-3156
A2K29			NOT ASSIGNED		
A2K31			NOT ASSIGNED		
A2R32	0757-0199	2	R:FXD MET FLM 21.5K OHM 1% 1/8W	28480	0757-0199
A2K33	0757-0442		R:FXD MET FLM 10.0K OHM 1% 1/8W	28480	0757-0442
A2R34	0757-0465		R:FXD MET FLM 100K OHM 1% 1/8W	28480	0757-0465
A2R35	0698-3454	1	R:FXD MET FLM 215K OHM 1% 1/8W	28480	0698-3454
A2R36	0757-0461	6	R:FXD MET FLM 68.1K OHM 1% 1/8W	28480	0757-0461
A2R37	0757-0470	1	R:FXD MET FLM 162K OHM 1% 1/8W	28480	0757-0470
A2R38	0757-0442		R:FXD MET FLM 10.0K OHM 1% 1/8W	28480	0757-0442
A2R39	0698-3155	2	R:FXD MET FLM 4.64K OHM 1% 1/8W	28480	0698-3155
A2R40	0698-3155		R:FXD MET FLM 4.64K OHM 1% 1/8W	28480	0698-3155
A2R41	0757-0465		R:FXD MET FLM 100K OHM 1% 1/8W	28480	0757-0465
A2R42	0757-0461		R:FXD MET FLM 68.1K OHM 1% 1/8W	28480	0757-0461
A2R43	0757-1094	1	R:FXD MET FLM 1.47K OHM 1% 1/8W	28480	0757-1094
A2R44	0757-0461		R:FXD MET FLM 68.1K OHM 1% 1/8W	28480	0757-0461
A2R45	0757-0465		R:FXD MET FLM 100K OHM 1% 1/8W	28480	0757-0465
A2K46	0757-0465		R:FXD MET FLM 100K OHM 1% 1/8W	28480	0757-0465
A2R47	0757-0461		R:FXD MET FLM 68.1K OHM 1% 1/8W	28480	0757-0461
A2R48	0757-0465		R:FXD MET FLM 100K OHM 1% 1/8W	28480	0757-0465
A2R49	0757-0461		R:FXD MET FLM 68.1K OHM 1% 1/8W	28480	0757-0461
A2R50	0757-0280		R:FXD MET FLM 1K OHM 1% 1/8W	28480	0757-0280
A2K51	0698-3260		R:FXD MET FLM 464K OHM 1% 1/8W	28480	0698-3260
A2R52	0757-0279		R:FXD MET FLM 3.16K OHM 1% 1/8W	28480	0757-0279
A2R53	0698-3160		R:FXD MET FLM 31.6K OHM 1% 1/8W	28480	0698-3160
A2R54	0698-3428	1	R:FXD MET FLM 14.7 OHM 1% 1/8W FACTORY SELECTED PART	28480	0698-3428
A2R54			FACTORY SELECTED PART		
A2K55	0698-3160		R:FXD MET FLM 31.6K OHM 1% 1/8W	28480	0698-3160
A2R55			FACTORY SELECTED PART		

See introduction to this section for ordering information

Table AI-3. Back-dating for Table 6-1 (Change C)

Reference Designation	HP Part Number	Qty	Description	Mfr Code	Mfr Part Number
A2R56	0698-3260		R:FXD MET FLM 464K OHM 1% 1/8W	28480	0698-3260
A2R57	0757-0442		R:FXD MET FLM 10.0K OHM 1% 1/8W	28480	0757-0442
A2R58	0698-3260		R:FXD MET FLM 464K OHM 1% 1/8W	28480	0698-3260
A2R59	0698-3260		R:FXD MET FLM 464K OHM 1% 1/8W	28480	0698-3260
A2R60	0698-0084	1	R:FXD MET FLM 2.15K OHM 1% 1/8W	28480	0698-0084
A2R61	0698-3260		R:FXD MET FLM 464K OHM 1% 1/8W	28480	0698-3260
A2R62	0698-3260		R:FXD MET FLM 464K OHM 1% 1/8W	28480	0698-3260
A2R63	0698-3260		R:FXD MET FLM 464K OHM 1% 1/8W	28480	0698-3260
A2R64	0757-0439	1	R:FXD MET FLM 6.81K OHM 1% 1/8W	28480	0757-0439
A2R65	0757-0442		R:FXD MET FLM 10.0K OHM 1% 1/8W	28480	0757-0442
A2R66	0757-0461		R:FXD MET FLM 68.1K OHM 1% 1/8W	28480	0757-0461
A2R67	0698-3160		R:FXD MET FLM 31.6K OHM 1% 1/8W	28480	0698-3160
A2R68	0757-0442		R:FXD MET FLM 10.0K OHM 1% 1/8W	28480	0757-0442
A2R69	0698-3438	1	R:FXD MET FLM 147 OHM 1% 1/8W	28480	0698-3438
A2R70	0698-3156		R:FXD MET FLM 14.7K OHM 1% 1/8W	28480	0698-3156
A2R71	0698-3160		R:FXD MET FLM 31.6K OHM 1% 1/8W	28480	0698-3160
A2R72	0698-3444	1	R:FXD MET FL4 316 OHM 1% 1/8W	28480	0698-3444
A2R73	0757-0199		R:FXD MET FLM 21.5K OHM 1% 1/8W	28480	0757-0199
A2R74	2100-1769	1	R:VAR WW 50 OHM 5% TYPE H 1W	28480	2100-1769
A2R75	0698-4466	1	R:FXD MET FL4 976 OHM 1% 1/8W	28480	0698-4466
A2R76	0757-0346		R:FXD MET FLM 10 OHM 1% 1/8W	28480	0757-0346
A2R77	0698-3160		R:FXD MET FLM 31.6K OHM 1% 1/8W	28480	0698-3160
A2R78	0811-2277	2	R:FXD WW 10K OHM 0.1% 1/40W	28480	0811-2277
A2R79	0811-2277		R:FXD WW 10K OHM 0.1% 1/40W	28480	0811-2277
A2R80	0811-2537	1	R:FXD WW 5K OHM 0.1% 1/40W	28480	0811-2537
A2R81	0757-0465		R:FXD MET FL4 100K OHM 1% 1/8W	28480	0757-0465
A2R81			FACTORY SELECTED PART		
A2R82	0757-0401	1	R:FXD MET FLM 100 OHM 1% 1/8W	28480	0757-0401
A2R83	0698-3441		R:FXD MET FL4 215 OHM 1% 1/8W	28480	0698-3441
A2R84	0757-0280		R:FXD MET FLM 1K OHM 1% 1/8W	28480	0757-0280
	0360-0124	1	TERMINAL:SOLDER LUG	28480	0360-0124

See introduction to this section for ordering information

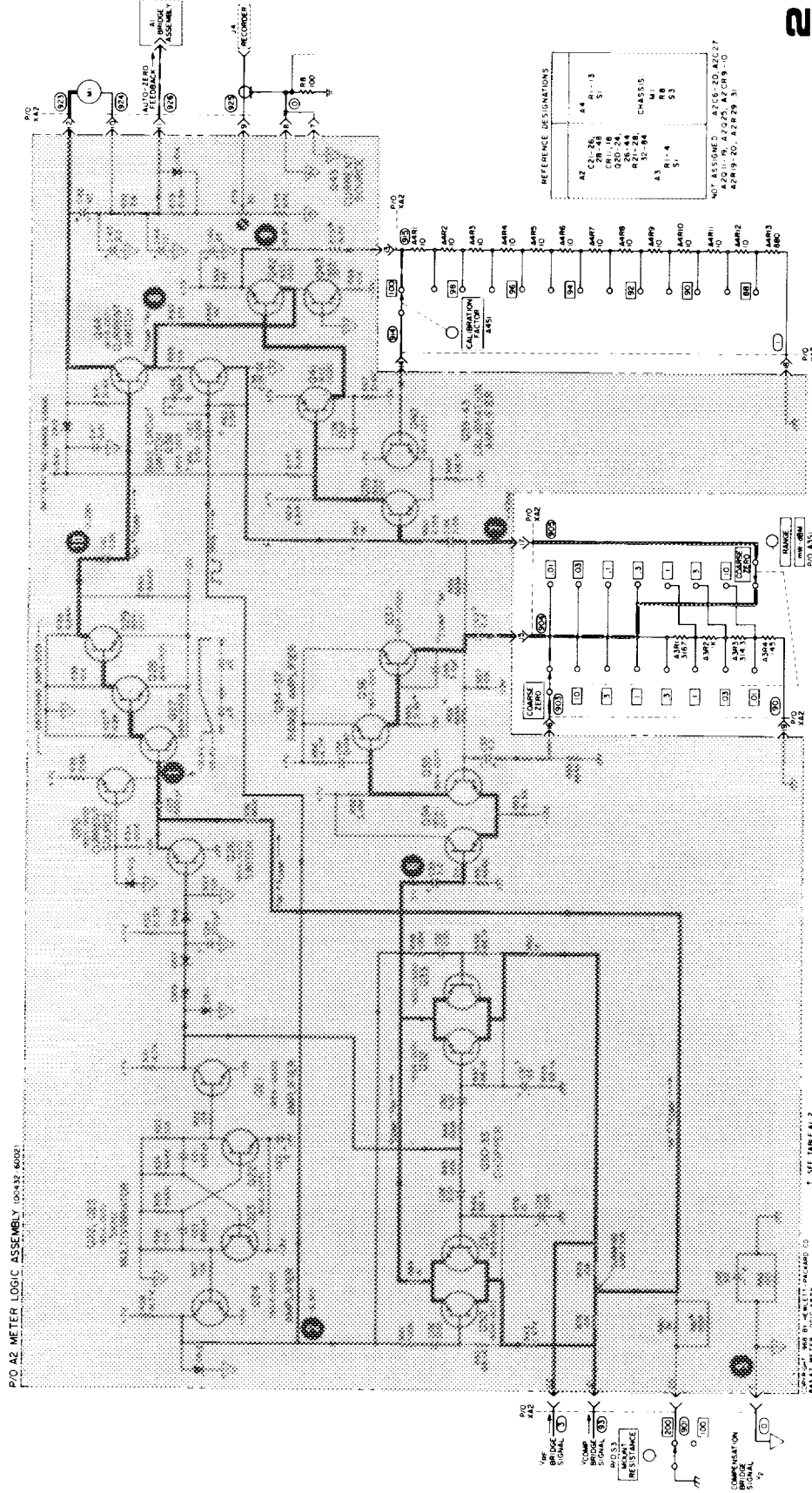

2

Figure AI-1. Meter Logic Schematic

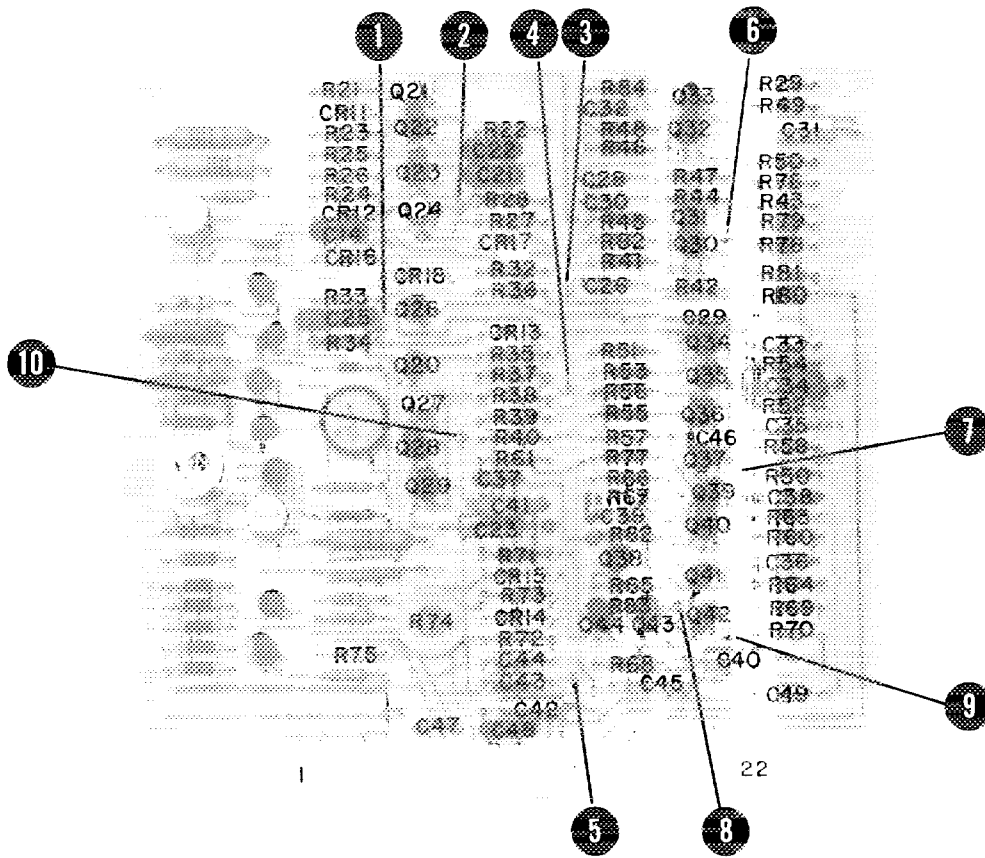

Figure AI-2. A2 Meter Logic Assembly Component Locations Back-Dating (Change C)

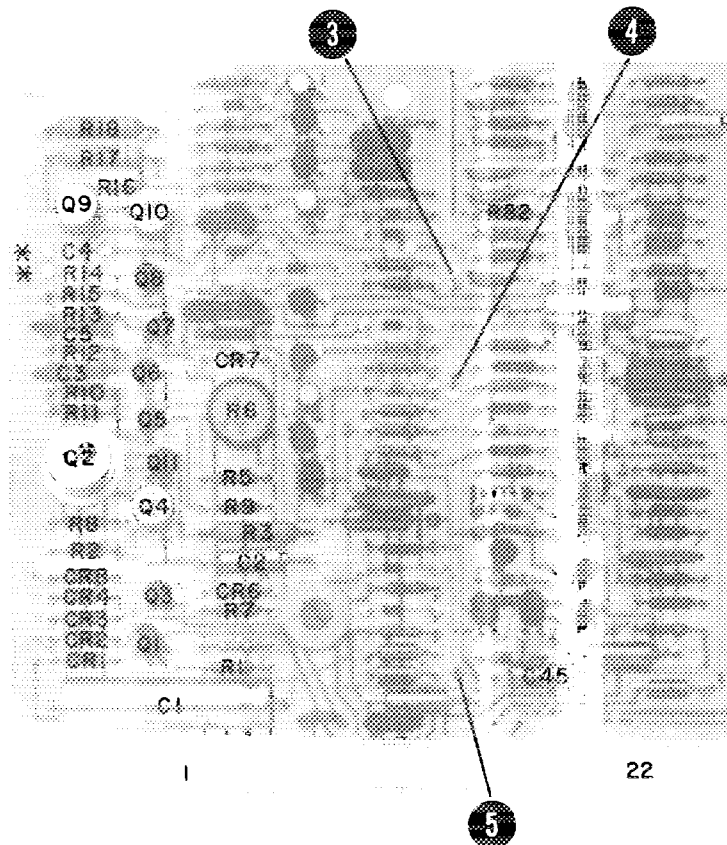

Figure AI-3. A2 Meter Logic Assembly, Power Supply Component Locations Back-Dating (Change C)

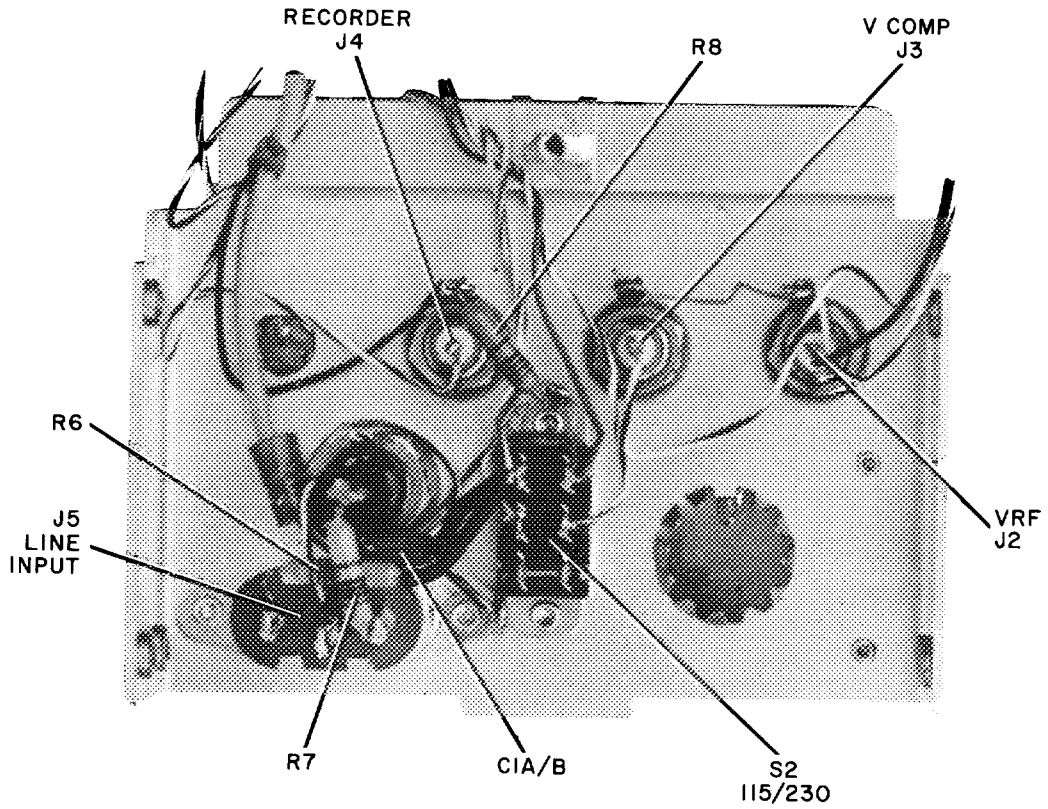

Figure AI-4. 432A Rear Panel Interior Back-Dating (Change G)

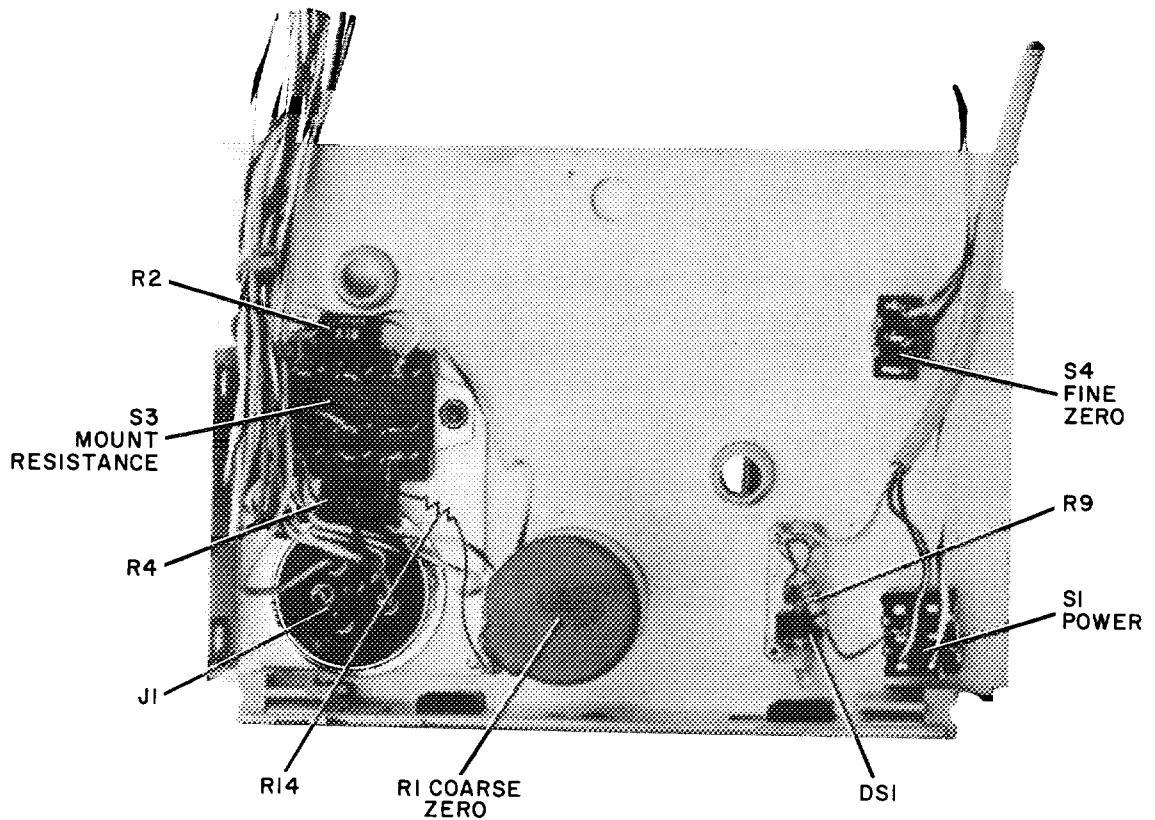

Figure AI-5. 432A Front Panel Interior Back-Dating (Change I)





## APPENDIX II

### INSTALLATION OF LONG CABLE OPTIONS

AII-1. Information in this appendix describes installation of the long cable options used with the 432A Power Meters. Table AII-1 lists the options, cable length and stock numbers. After completion of the installation procedures, the power meter should be recalibrated using the procedures in Section V of this manual.

**NOTE**

These cable option kits are for mount resistances of either 100 or 200 ohms.

AII-2. Depending on the option selected, the following components are added or replaced with parts supplied with the option kits:

- a. C2
- b. R10, R11, R12 and R13
- c. A1R32 and A1R42
- d. A2C45

AII-3. The following equipment is required for the installation of the long cable options:

- a. Soldering Tool, wattage rating: 37.5
- b. De-soldering aid
- c. Pozidriv screwdriver (small)
- d. Pozidriv screwdriver (medium)

AII-4. No substitution can be made for long cables listed in Table AII-1. Long cables from the older power meters, such as the 431 series, cannot be interchanged with 432A long thermistor cables because of resistance variations.

AII-5. If a long cable option of 20-feet or longer is used with a *balanced* thermistor mount such as the HP 8478B, pins 2 and 4 must be shorted at the mount end of the cable. This short can be accomplished with an 11527A Adapter available from Hewlett-Packard. The 11527A, connected between the mount and the cable, can be removed for instrument operation with an unbalanced mount.

**NOTE**

If a 432A has been modified for a particular cable option, it is incompatible with all other cable lengths.

AII-6. The parts required for the modification are listed in Table 6-1 and shown on the appropriate Service Sheet.

**AII-7. OPTION 009 INSTALLATION.**

AII-8. Option 009 (10-foot cable) requires no modification to the 432A Power Meter. The longer cable is substituted for the standard five-foot thermistor cable.

**AII-9. OPTION 010 INSTALLATION.**

a. Remove the right side and top covers from the 432A. Remove the A1 Bridge Assembly circuit board from the instrument.

b. Referring to Figure 7-7, locate the board position where A1R42 is to be placed. Install the 261K, 1%, 0.125W resistor, supplied with the kit, in that position.

c. Place the modification decal on the top center of the front panel.

d. This completes the Option 010 installation. Before replacing the top and side panels, connect the ten-foot cable and perform the bridge amplifier adjustments in Section V of this manual.

Table AII-1. 432A Power Meter Long Cable Options

Option	Kit Number	Cable Length (feet)
009	00432-6018	10
010	00432-6019	20
011	00432-6020	50
012	00432-6021	100
013	00432-6022	200

**AII-10. OPTION 011 THROUGH 013 INSTALLATION.**

a. Remove both side, top and bottom covers. Remove the A1 Bridge Assembly.

b. Locate the printed circuit board eyelets in which A1R32 and A1R42 are to be placed by referring to Figure 7-7. Note that one end of these resistors will be placed inside the guard rings that attach to the bases of A1Q12B and A1Q7B. There is a vacant eyelet provided inside the guard rings to make this connection.

c. Install the correct value A1R32 and A1R42 for the desired option.

d. Place the 432A on its top; Figure 7-5 reveals the location of bridge resistors R3 and R5 on terminal strip XA1. Select the proper values of resistors R10 and R11 from the option kit. Solder R11 across pins 3 and 5 of XA1 in parallel with R5 and solder R10 across pins 6 and 8 of XA1 in parallel with R3.

e. Locate the MOUNT RESISTANCE switch S3 on the back of the front panel. Bridge resistors R2 and R4 are wired to the rear of S3

(see Figure 7-6). Choose the resistors supplied with the option kit for R12 and R13. Solder R12 across R2 and R13 across R4.

f. Capacitor C2 (2.2  $\mu$ F) is connected across the rear of the FINE ZERO switch S4 (see Figure 7-6). With the instrument resting on its top, wire the positive lead of C2 to the terminal of S4 with the white/black/violet (907) wire and the negative lead to the terminal with the violet (7) wire.

g. Remove the A2 Meter Logic Board. A2C45 by referring to Figure 7-11.

Remove the 60  $\mu$ F capacitor and replace it with the 300  $\mu$ F capacitor supplied with the option kit. Observe the polarity as marked on the circuit board.

h. Place the modification decal on the top center of the front panel.

i. This completes the modification. Install the A1 and A2 boards back in the instrument. Perform the adjustment procedures in Section V of this manual with the long cable.